

Data Sheet

DS-LP-MC1000-CLLT-eng

November, 2009

Type MC1000

Continuous Liquid Level Transmitters

Features and Benefits

- Versatile construction - 316SS, PVC or PVDF compatible with many fluids
- Flanged or threaded tank connections provides flexible mounting options
- Economical continuous measurement

Description

A float fitted with a magnet slides along a guide tube and follows the fluid level. The float unit consists of a magnet-carrying float installed around a stainless steel tube. As the float moves up or down on the tube, a reed switch chain is actuated inside the guide tube.

Reed switches act as a variable resistance. The variable resistance signal is converted into an analog 4-20mA signal by a 2 wire loop powered transducer. The current output is proportional to the liquid level in the tank. The transducer is installed in a standard or flame-proof ATEX housing outside of the tank. An Intrinsically Safe version is also available.



Continuous Liquid Level Transmitter

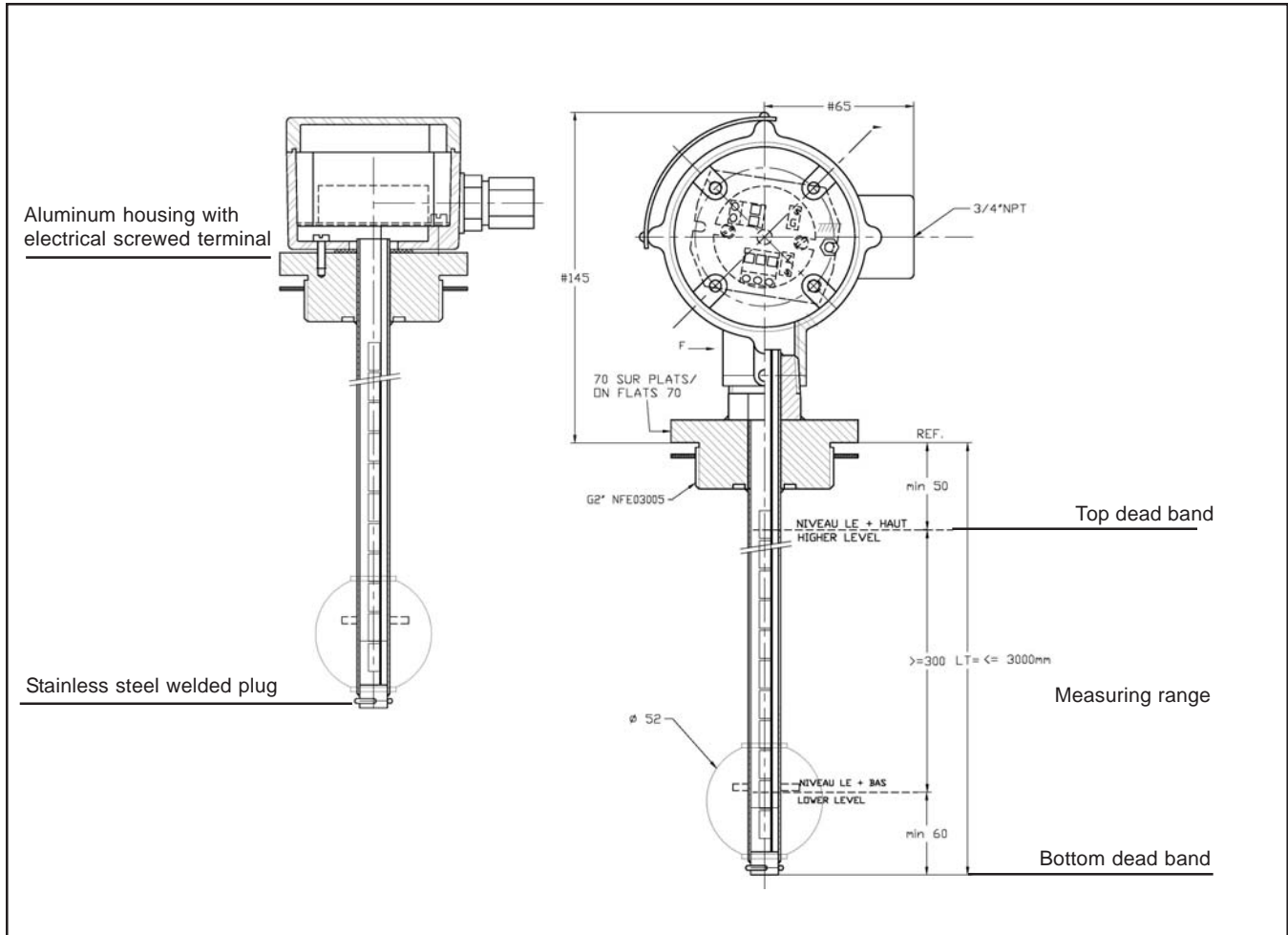

Model MC1000 Designs

Operating Conditions

TYPE	MC1000 (ST.STEEL)	MC1000 PVC	MC1000 PVDF
Minimum Specific Gravity	0.75	0.8	0.8
Maximum Temperature	70°C (158°F)	40°C (109°F)	70°C (158°F)
Maximum Pressure	32 bar (464 psi)	3 bar (93 psi)	3 bar (93 psi)

Note: For flanged connections maximum operating conditions have to be in conformity with flange rating.

Continuous Liquid Level Transmitter

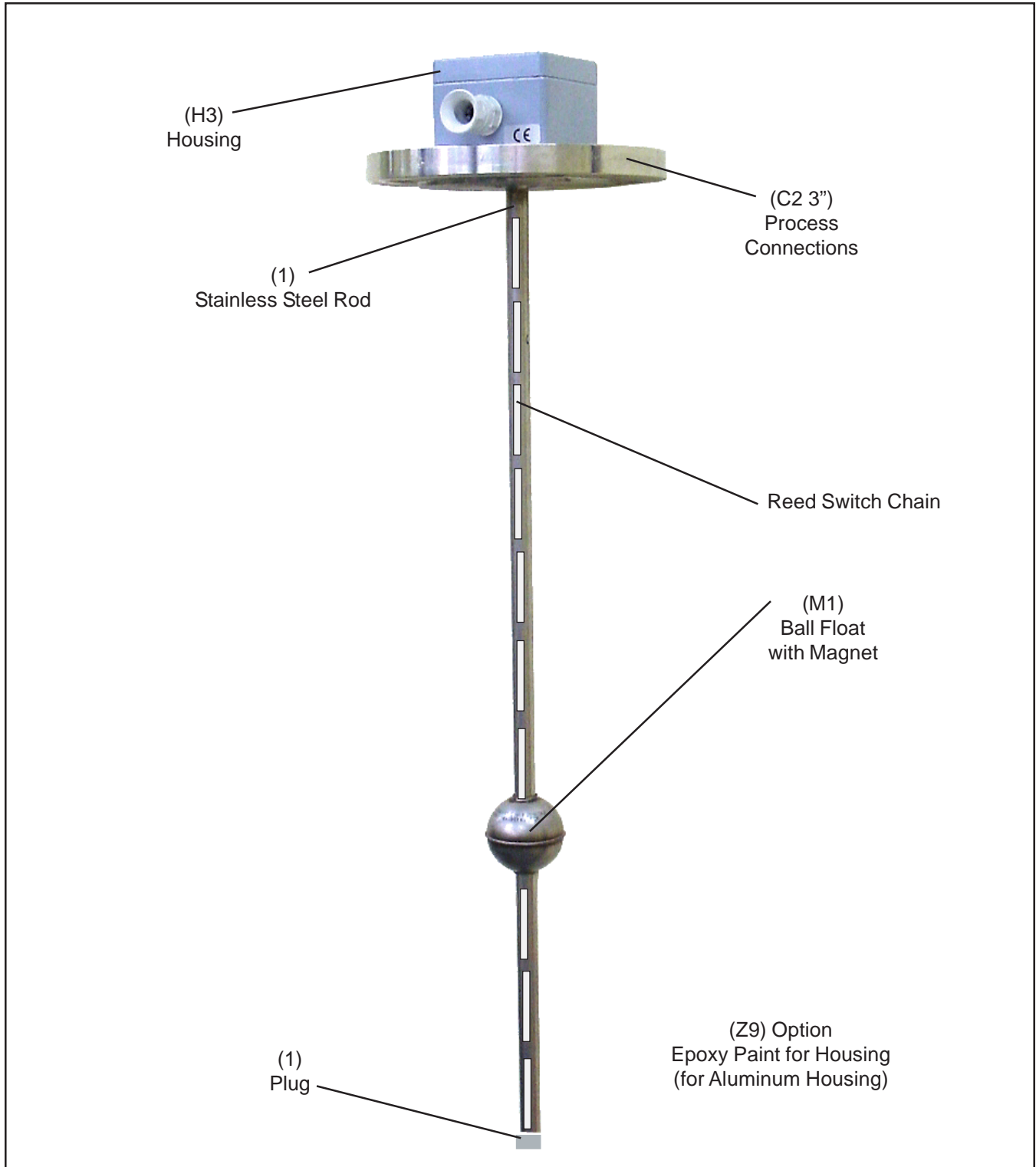

Model MC1000 Components

Example: MC1000 Component Codes

MC1000	1	3"	M1	C2	H3	T6	Z9
Instrument Code	Material	Connection Size	Float Type	Connection Type	Housing Type	Transmitter Type	Option

Continuous Liquid Level Transmitter

MC1000-1
 Aluminum
 Housing Version
 IP65
 Flange Process Connection
 (represented Model)

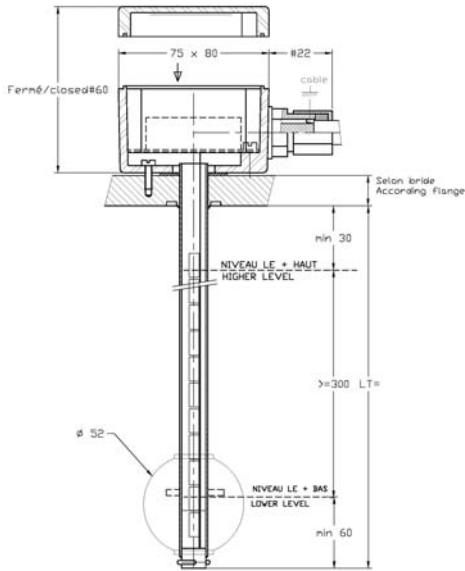

MC1000-1
 Stainless Steel
 Housing Version
 IP65
 Flange Process Connection
 (represented Model)

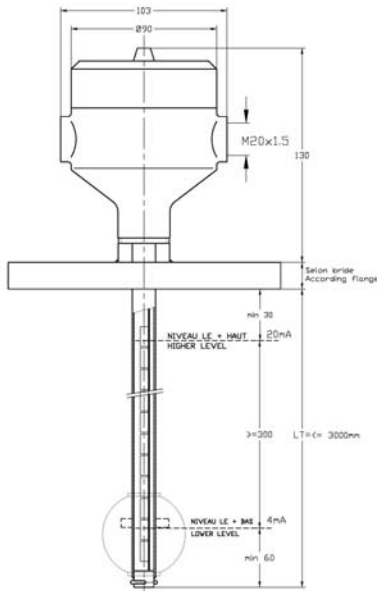

MC1000-1
 MC1000 for 810 Versions
 IP65 in Standard
 (represented Model 1)
 See Data Sheet for MLG 810

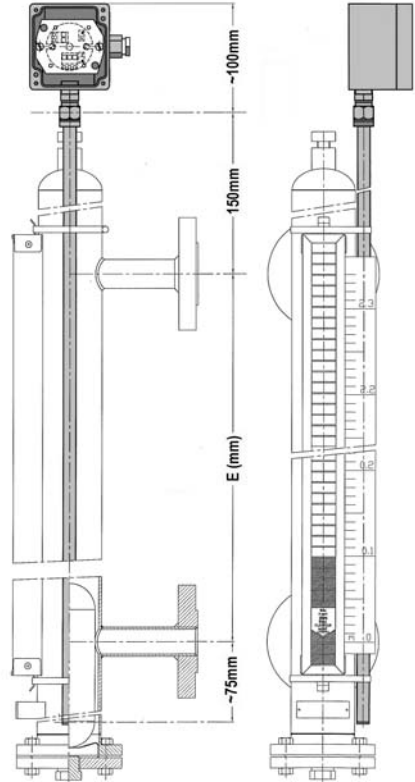

MC1000-1
 Aluminum Explosion-Proof
 Version IP65
 (represented Model)
 2" Threaded
 Process Connection

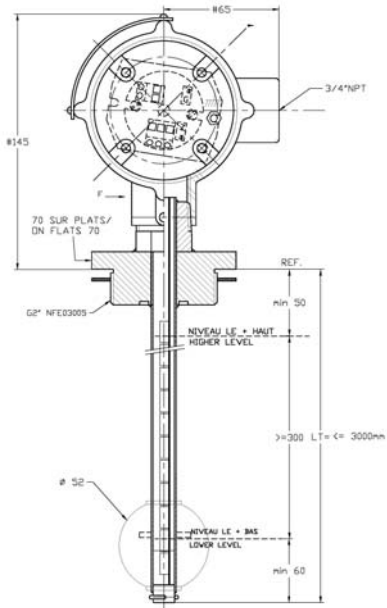

MC1000-PVC/PVDF
 Aluminum
 Housing Version
 IP65
 Flange Process Connection
 Wetted Part PVC or PVDF

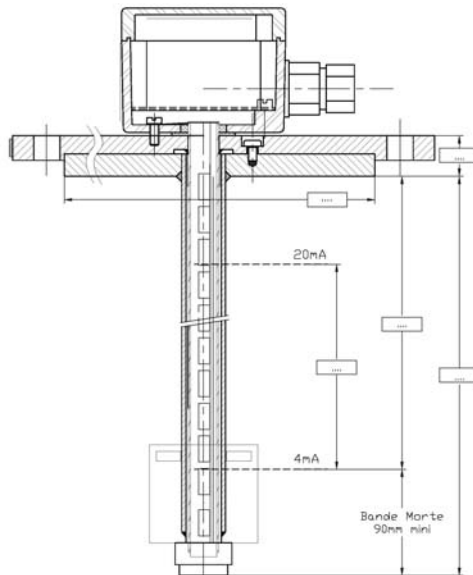

Model MC1000 Dimensions

Data Sheet

DS-LP-MC1000-CLLT-eng

November, 2009

Continuous Liquid Level Transmitter

Product Specifications and Certifications

Pressure Equipment Directive (PED) Sound Engineering practice

Standard design:

Fluid: liquid group = 1 or 2

Max pressure = (See Table Operating Conditions)

Max D.N. = (See Table Model Code)

PED category = 33

Process Connection:

- Threaded plug 2" BSPP or NPT
- Flange PN16/PN 20 ...according to codification (29203 standard)
- On request, others connection types and sizes

Housings Selection

Type	Standard IP65
Dimensions (LxIxh)	80mm x 75mm x 57mm
Material	Aluminium
Rod	Ø 14mm 316L St. St. on ¾" NPT brass connection
Connection	PG9 Polyamid cable gland for Ø 5 à 9mm cables
Protection	IP65 – 4 screws cover
Coating	Polyester paint

Type	B4 – Explosion Proof ("d")
Dimensions (LxIxh)	See drawing to the right
Material	Aluminium
Rod	Ø 14mm 316L St. St. ¾" NPT
Connection	¾"NPT Aluminium cable gland (Ø 5 à 12mm cables) (supplied) ATEX certified ("d")
Protection	IP65/IP66 – screwed cover
Coating	No – Raw Aluminium finish
Certificate	ATEX N° LCIE01ATEX6060X IECEX LCI09 0017X
Marking**	⊕ II 2G ExdIICT6
Electrical data	Supply Max.: 230V Current Max.: 15A Power Max.: 20W
Temperature	Ta = -40°C = +75°C
Name Plate	Aluminium / St. St rivets

Type	Intrinsically Safe ("ia")*
Dimensions (LxIxh)	See below drawing
Rod	Ø 14mm 316L St. St. on ¾" NPT brass connection
Connection	PG9 Polyamid blue cable gland for Ø 5 à 8 m cables (Exe certified)
Protection	IP65
Coating	Polyester paint
Certificate	ATEX N° LCIE05ATEX6034X IECEX LCI 08.0048x
Marking **	⊕ II 1 G ExiallCT6/T5/T4
Electrical data	Ui≤30V; Ii≤101mA; Pi≤758mW Or Ui≤28,4V; Ii≤116mA; Pi≤824mW Ci=0nF ; Li=0mH
Temperature	T6: Ta=50°Cmax./ T5:Ta=65°Cmax./ T4: Ta=80°Cmax.
Name Plate	Aluminium / St. St rivets

Type	ISA - 316L Stainless Steel
Dimensions (Øxh)	Ø 103mm, h=117mm
Rod	Ø 14mm 316L St. St.
Connection	M20x1,5 cable gland (cables Ø 5 à 9mm)
Protection	IP67– screwed cover
Coating	No - Raw Stainless steel finish

Explosion proof "d" certified version

Marking***	⊕ II 2G ExdIICT6
Certificate	ATEX "d" LCIE 01ATEX 6060X IECEX LCI 09.0017X
Connection	M20x1,5 cable gland "d" certified
Protection	IP67– screwed cover
Coating	No - Raw Stainless steel finish

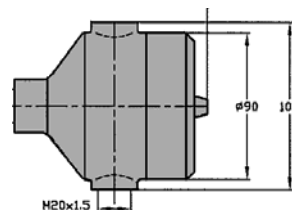
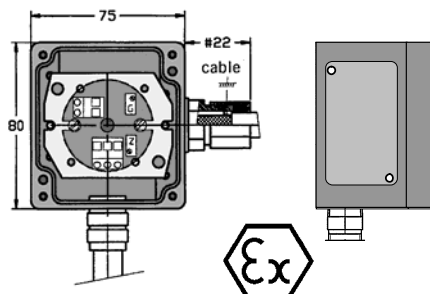
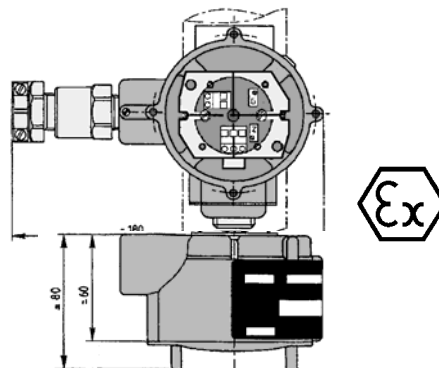
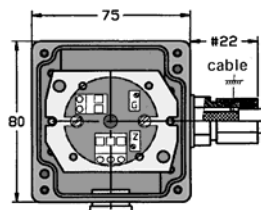

* The transmitter electrical unit must be chosen among the ATEX IS certified units (see next page)

** The ATEX marking complies with the 94/09/EC Directive and certify the transmitter, the reed switch line and the housing.

*** The ATEX marking complies with the 94/09/EC Directive and certify the reed switch line and the housing

Continuous Liquid Level Transmitter

Type MC1000 Specifications and Certifications

Transmitter range	
Type	XT42-NIV (standard)
Output	4-20mA 2 wires
Maximum Range	5,5 m
Power Supply	12V < V < 30V
Temperature	-20°C < T < 70°C
Accuracy	0,15% full scale
Resolution	15mm

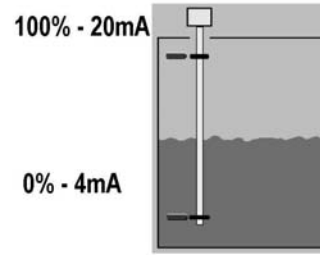

Type	XT42-NIV I.S.
Output	4-20mA 2 wires
Maximum Range	5,5 m
Power Supply	12V < V < 30V
Temperature	-20°C < T < 65°C
Accuracy	0,15% full scale
Resolution	15mm
ATEX Certified	Intrinsically safe EExia

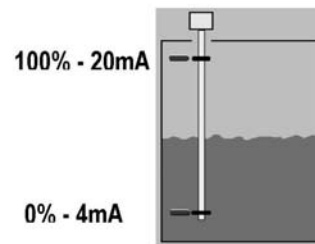

Types	
	XT PRO-HART
	XT PRO-HART LIN
Output	4-20mA 2 wires
Maximum Range	5,5 m
Power Supply	9,5V < V < 30V
Temperature	-20°C < T < 70°C
Accuracy	0,1% full scale
Resolution	15mm
Protocol	HART
Data Acquisition	10/s
Burnout	3,8mA / 22mA
Linearization	XTPRO LIN version only

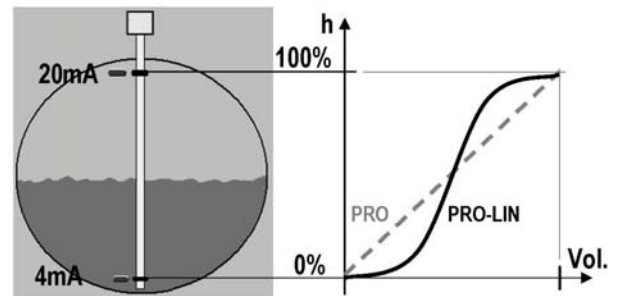

Types	
	XT PRO-HART S.I.
	XT PRO-HART LIN S.I.
Output	4-20mA 2 wires
Maximum Range	5,5 m
Power Supply	9,5V < U < 30V
Temperature	-20°C < T < 65°C
Accuracy	0,1% full scale
Resolution	15mm
Protocol	HART
Data Acquisition	10/s
Burnout	3,8mA / 22mA
Linearization	XTPRO LIN version only
ATEX Certified	Intrinsically Safe EExia

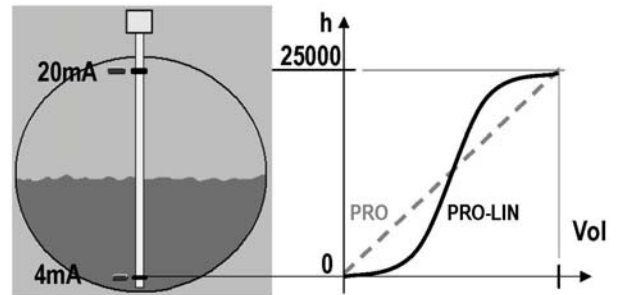

Measuring length

From 300mm to a maximum length of 2900mm in increments of 15mm. Provision has been made for a "dead band" (non measured zone, of 60 to 100mm depending on the model type) on the top and the bottom of the instrument.

Type MC1000 Model Code

CODE	WETTED PARTS MATERIAL	
MC1000 I	316L Stainless steel Version +float in 316Ti	
MC1000 PVC	PVC Version (wetside material)	
MC1000 PVDF	PVDF Version (wetside material)	
CODE	CONNECTION SIZE	
2"	BSPP or NPT thread – Stainless steel	
2"1/2	BSPP thread– PVC - PVDF	
65	ISO PN...DN65 – Stainless steel, PVC, PVDF	
80	ISO PN...DN80 – Stainless steel, PVC, PVDF	
100	ISO PN...DN100 – Stainless steel, PVC, PVDF	
125	ISO PN...DN125 – PVDF	
150	ISO PN...DN150 – PVDF	
2"1/2	ANSI B.16-5 DN 2 "1/2 - Stainless steel; PVC, PVDF	
3"	ANSI B.16-5 DN 3 "– Stainless steel, PVC, PVDF	
4"	ANSI B.16-5 DN 4 "– Stainless steel, PVC, PVDF	
5"	ANSI B.16-5 DN 5 "– PVDF	
6"	ANSI B.16-5 DN 6 "– PVDF	
CODE	FLOAT TYPE	
M1	316L Stainless steel	0,75 < SG < 1,6 p < 30bar (435 psi) T < 100°C (212°F)
M1	PVC	0,8 < SG < 1,6 p < 3bar (435 psi) T < 40°C (102°F)
M1	PVDF	0,8 < SG < 1,6 p < 3bar (435 psi) T < 100°C (212°F)
MX	special Float on request	
CODE	CONNECTION TYPE	
C1	thread	BSPP ou NPT
C2	Flange	ISO NP 16 DN...
C3	Flange	ANSI 150#NP20 DN...
C4	Flange	ANSI 300#NP50 DN...
CX	Special connection on request	
CODE	HOUSING TYPE	
H2	ATEX "ADF" EExd IIC T6 housing	
	T4	XT42 Standard
	T7	XT PRO HART
	T11	XT PRO HART+ Linearization
H3	Standard IP65 aluminium housing	
	T1	XT42
	T2	XT42 I S Eex ia IIC T6
	T5	XT PRO HART
	T6	XT PRO HART I S
	T9	XT PRO HART + Linearization
	T10	XT PRO HART I S + Linearization
H5	IP67 stainless steel housing	
	T1	XT42
	T2	XT42 S I Eex ia IIC T6
	T5	XT PRO HART
	T6	XT PRO HART I S
	T9	XT PRO HART + Linearization
	T10	XT PRO HART I S + Linearization
CODE	OPTIONS	
Z1	ATEX Explosion-Proof Cable gland for type H2 (3/4" NPT)	
Z9	Epoxy paint for housing (for aluminium housing)	
Z11	ADE4F Nickel brass cable glang for type H2 (3/4" NPT) cable 8.5 to 16	
Z12	ADE1F 316Lst. steel cable gland for type H5 (M20x1.5) cable 6 to 12	

MC1000 I	3"	M1	C2	H3	T6	Z9
----------	----	----	----	----	----	----

Continuous Liquid Level Transmitter

BROOKS SERVICE AND SUPPORT

Brooks is committed to assuring all of our customers receive the ideal flow solution for their application, along with outstanding service and support to back it up. We operate first class repair facilities located around the world to provide rapid response and support. Each location utilizes primary standard calibration equipment to ensure accuracy and reliability for repairs and recalibration. The primary standard calibration equipment to calibrate our flow products is certified by our local Weights and Measures Authorities and traceable to the relevant International Standards.

Visit www.BrooksInstrument.com to locate the service location nearest to you.

START-UP SERVICE AND IN-SITU CALIBRATION



Brooks Instrument can provide start-up service prior to operation when required. For some process applications, where ISO-9001 Quality Certification is important, it is mandatory to verify and/or (re)calibrate the products periodically. In many cases this service can be provided under in-situ conditions, and the results will be traceable to the relevant international quality standards.

CUSTOMER SEMINARS AND TRAINING

Brooks Instrument can provide customer seminars and dedicated training to engineers, end users and maintenance persons. Please contact your nearest sales representative for more details.

HELP DESK

In case you need technical assistance:

Americas	 1 888 554 FLOW
Europe	 +31 (0) 318 549 290
Asia	 +81 (0) 3 5633 7100

Due to Brooks Instrument's commitment to continuous improvement of our products, all specifications are subject to change without notice.

TRADEMARKS

Brooks Brooks Instrument, LLC



Brooks Instrument
407 West Vines Street
P.O. Box 903
Hatfield, PA 19440-0903 USA
T (215) 362-3700
F (215) 362-3745
E-Mail BrooksAm@BrooksInstrument.com
www.BrooksInstrument.com

Brooks Instrument
Neonstraat
6718 WX Ede, Netherlands
T +31 318 549 300
F+ 31 318 549 309
E-Mail BrooksEu@BrooksInstrument.com

Brooks Instrument
1-4-4 Kitasuna Koto-Ku
Tokyo, 136-0073 Japan
T +81 (0) 3 5633 7100
F +81 (0) 3 5633 7101
E-Mail BrooksAs@BrooksInstrument.com

Brooks Instrument S.A.S.
Z.A.de la Tour - ABREST -France
T +33 (0)4 70 59 81 81
F +33 (0)4 70 59 96 37
www.BrooksInstrument.com