

Brooks® Seal Free Pressure Measurement for Ultrapure Fluids

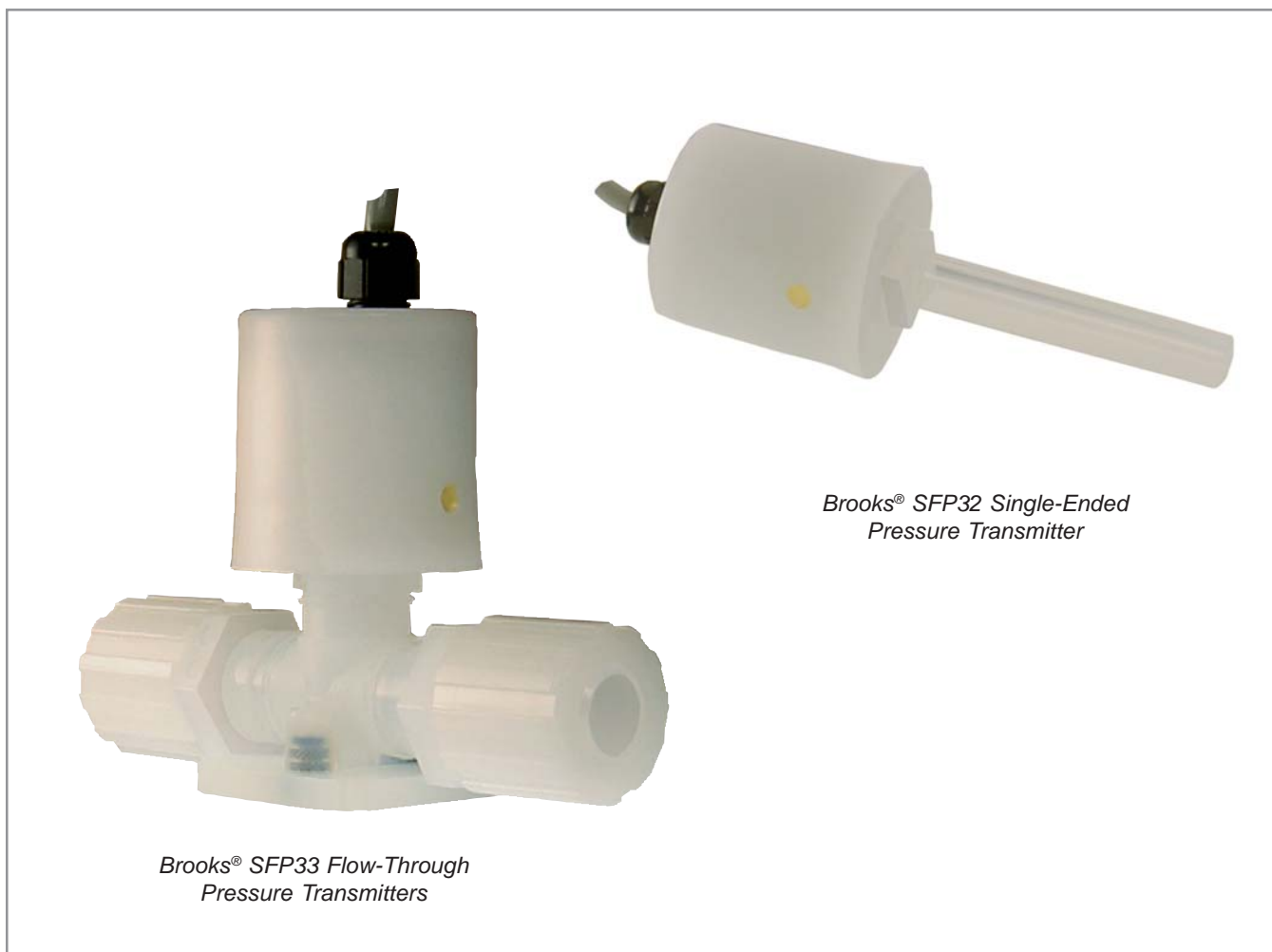

*Brooks® SFP33 Flow-Through
Pressure Transmitters*

*Brooks® SFP32 Single-Ended
Pressure Transmitter*

Brooks® SFP33 Flow-Through and SFP32 Single-Ended Pressure Transmitters

Brooks® SFP

Brooks® Seal Free Pressure (SFP) transmitter is designed to measure the pressure of high purity fluids. It comes in two versions, the WA designation is for measuring ultrapure water and the CA designation is for measuring ultrapure chemicals, acids and bases.

The heart of the transmitter is an injection molded, single piece, pressure vessel fabricated from high purity Perfluoroalkoxy (PFA) plastic. The design allows the PFA diaphragm to be thick, while still providing pressure sensitivity and insuring process safety. The thick diaphragm virtually eliminates the possibility of corrosive ions diffusing from the process fluid. Injection molding provides a very smooth surface finish to maintain fluid purity. No elastomers are used to seal the pressure sensor from the process fluid. The benefit is increased fluid purity since elastomers can be a possible contamination source in ultrapure fluids. There are no potential fluid leak paths to the outside in this innovative design.

An alumina NANO-composite ceramic pressure sensor is permanently bonded to the PFA pressure diaphragm. It is highly corrosion resistant to the chemicals used in semiconductor manufacturing, which further insures fluid purity. Permanent bonding of the pressure sensor to the PFA diaphragm means exposure to a vacuum will not damage the transmitter. Measurement in the vacuum region is also possible.

In the unlikely event that corrosive ions penetrate the PFA diaphragm, a patent pending integrated vapor leak indicator is mounted in the wall of the sealed electrical housing. This indicator will change colors in the presence of corrosive ions and provide a primary visual indication that the sensor electronics have been compromised and thus the device should be replaced. Sensor electronics are protected to IP55 standards.

Brooks® SFP has the flexibility to fit your process and electrical interfacing requirements. A wide variety of standard pressure ranges are available and can be referenced to either atmospheric pressure for gauge measurement or a vacuum for absolute measurement. Externally accessed zero and span adjustments are provided to compensate the device for mounting effects. This also allows the user to recalibrate the device without having to send it back to the factory. Temperature compensation electronics insure accurate pressure measurement over a range of process

temperatures. Voltage and current electrical signals representing measured pressure are available. A variety of fluid connections can be specified.

Applications

The Brooks® SFP is available as either a single-ended design (32 designation) or a flow-through design (33 designation). The Brooks® SFP WA is specifically designed for measuring the pressure of ultrapure water used in industries where maintaining metal ion free water is a high priority for process consistency and yield. These industries include semiconductor, flat panel display and optics. The Brooks® SFP CA is designed for measuring the pressure of ultrapure chemicals used in these same industries.

Precision Pressure Measurement

The ceramic pressure sensor provides an accurate and stable pressure measurement. Integrated temperature electronics compensate the pressure measurement for changing fluid temperatures. All devices are factory calibrated to the requested pressure range and are thoroughly tested over the specified operating temperature range.

Seal Free Process Connection

The single piece process connection means fluid is only in contact with pure PFA surfaces. This also increases process safety since there are no potential leak paths to the outside of the transmitter. Exposure to vacuum pressures will not damage the transmitter's performance. (See Figure 1)

High Purity Process Integrity

Process wetted surfaces are fabricated from injection molded PFA plastic. Injection molding creates a very smooth surface to insure fluid purity. No elastomeric seals are used, which eliminates a potential source of fluid contamination.

Flexible Applications

A variety of pressure ranges and process connections allow for flexibility to meet your process requirements. A choice of either a voltage or analog signal allows for easy interfacing with almost all control and monitoring electronics. Externally accessible zero and span adjustments can be used to adjust the sensor, after installation, to compensate for mounting and environmental factors.

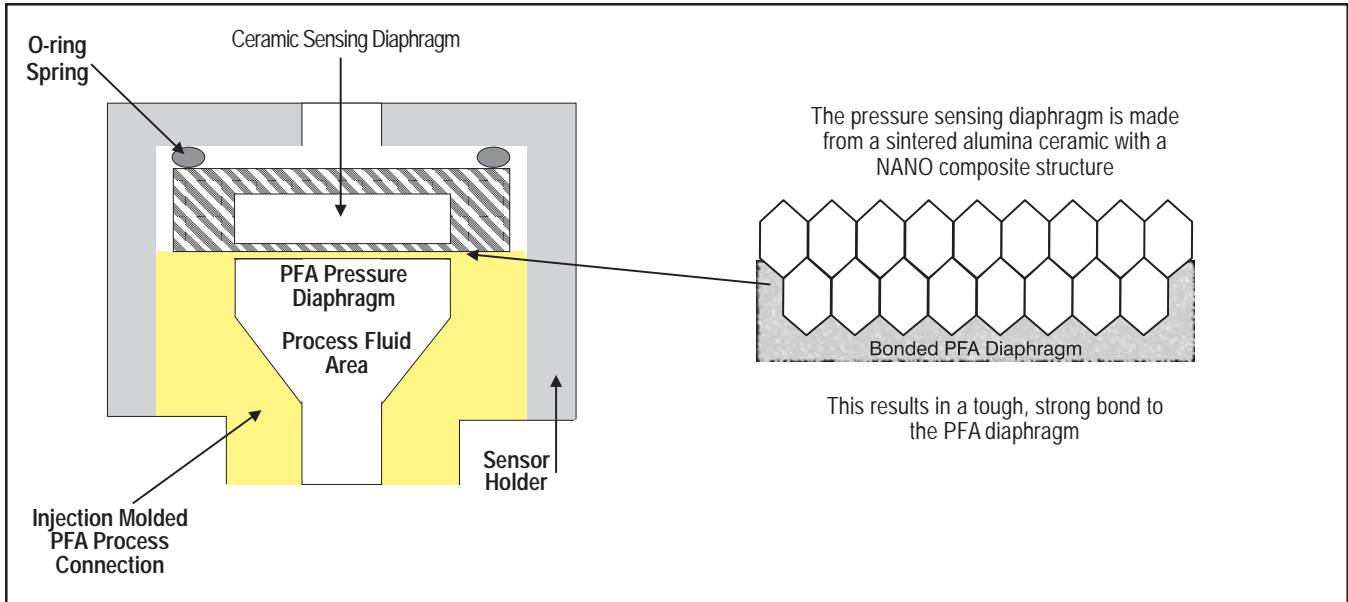

Figure 1 Design of the Pressure Sensor Assembly with the Ceramic Diaphragm Bonded to the PFA Diaphragm

SPECIFICATIONS

Performance Specifications

Pressure Measurement:

Standard Ranges Available:

0-150 psi*
0-145 psi*
0-100 psi
0-95 psi
0-60 psi
0-30 psi
0-15 psi**

Custom ranges optional (contact factory)

Gauge pressure measurement is standard

Absolute pressure measurement is an option

Accuracy: +/- 1% full scale includes linearity, hysteresis, and repeatability

Temperature Compensation Range: 15-40°C (59-104°F)

Temperature Drift: +/- 0.3% Full Scale per degree °C

* Note: 150 psi and 145 psi ranges are available only in the Ultrapure Water models 32 WA and 33 WA.

** Note: Gauge pressure only

Brooks® SFP

Physical Specifications

Materials of Construction:

Process wetted: High purity perfluoroalkoxy PFA plastic

Electrical Enclosure: Polypropylene

Pressure Sensor: Al₂O₃

Process Connections:

PFA tube stub is standard

Options:

Male Flaretube

Male and Female NPT threaded (WA Version only)
(See Table 1 Ordering Information)

Ceramic Sensor Proof Pressures:

Proof pressure of the ceramic diaphragm is the maximum exposure pressure without damaging the sensor performance.

Range	Proof Pressure
0-15 psig	22.5 psig
0-30 psig	37.5 psig
0-60 psig	112 psig
0-95 psig	178 psig
0-100 psig	178 psig
0-145 psig	187 psig
0-150 psig	187 psig

Leak Pressures:

Minimum pressure at which the transmitter might leak.

Range	Leak Pressure
0-15 psig	42 psig
0-30 psig	85 psig
0-60 psig	180 psig
0-95 psig	375 psig
0-100 psig	375 psig
0-145 psig	375 psig
0-150 psig	375 psig

Functional Specifications

Pressure Output Signals:

4-20 mA, 0-5 V, 1-5 V and 0-10 V are available for pressure measurement in the range specified.

Voltage Input Requirements:

24 Vdc for current output
12-24 Vdc for voltage output

Protection:

IP55 equivalent
Meets CE standards

EMC Directive 89/336/EEC

Pressure Equipment Directive 97/23/EC as Sound Engineering Practice (SEP).

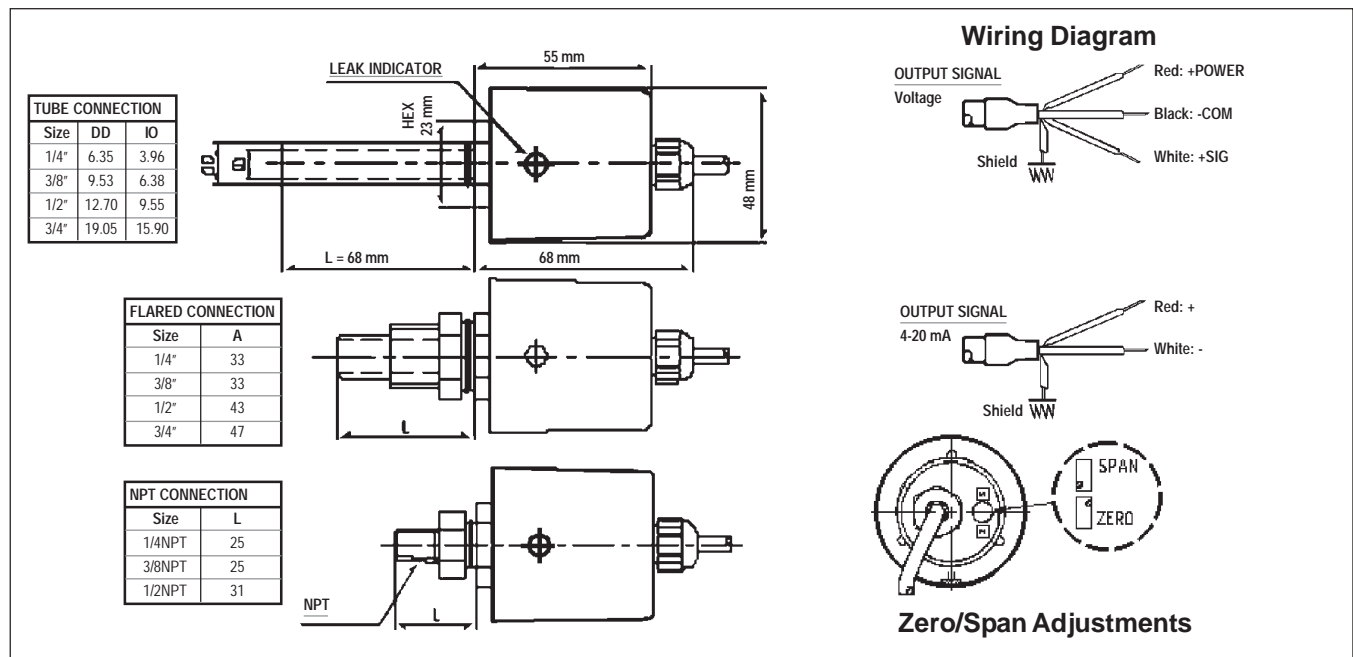

Figure 2 Dimensional Drawing of the Brooks® Model SFP32, Single-Ended Pressure Transmitter.

Note: Wiring Diagram and Zero/Span Adjustments apply to all models

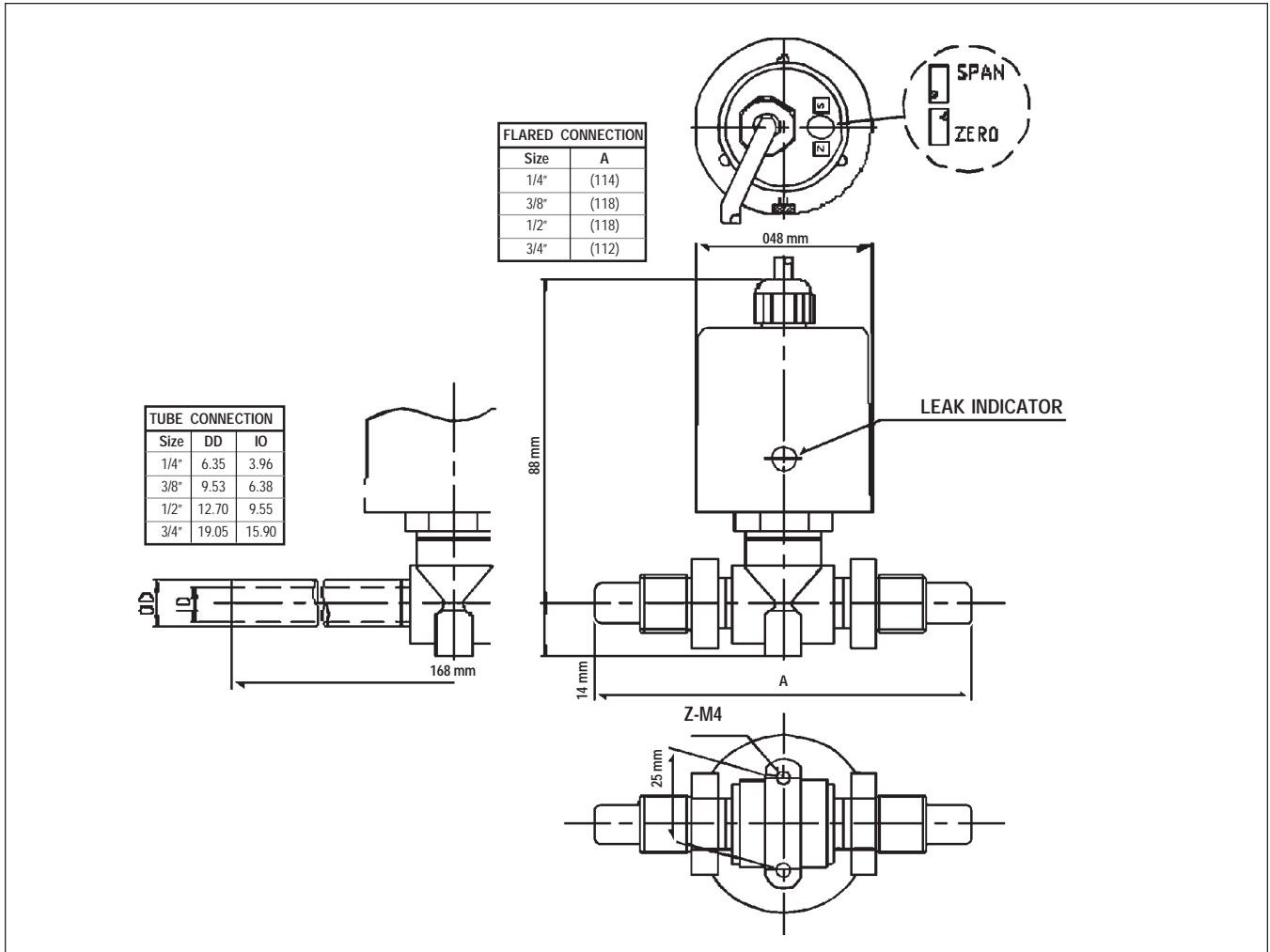

Figure 3 Dimensional Drawing of the Brooks® Model SFP33, Flow-Through Pressure Transmitter with Flare and Tube Process Connections.

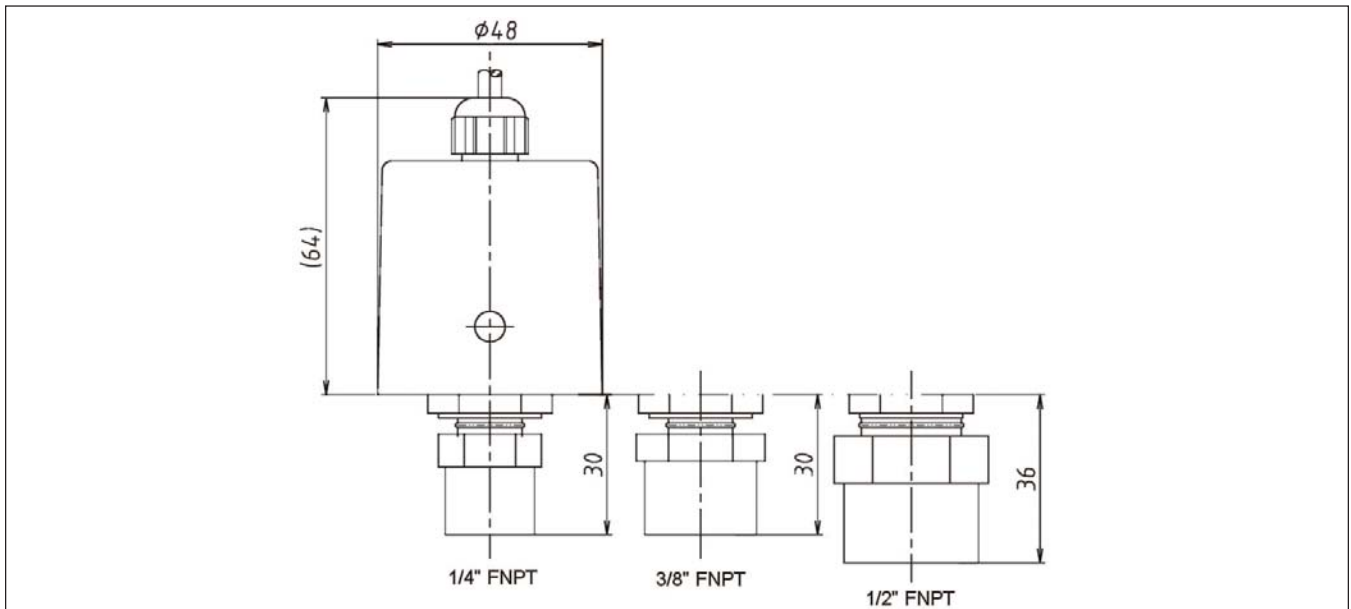

Figure 4 Dimensional Drawing of the Brooks® Model SFP32 Female NPT Fittings.

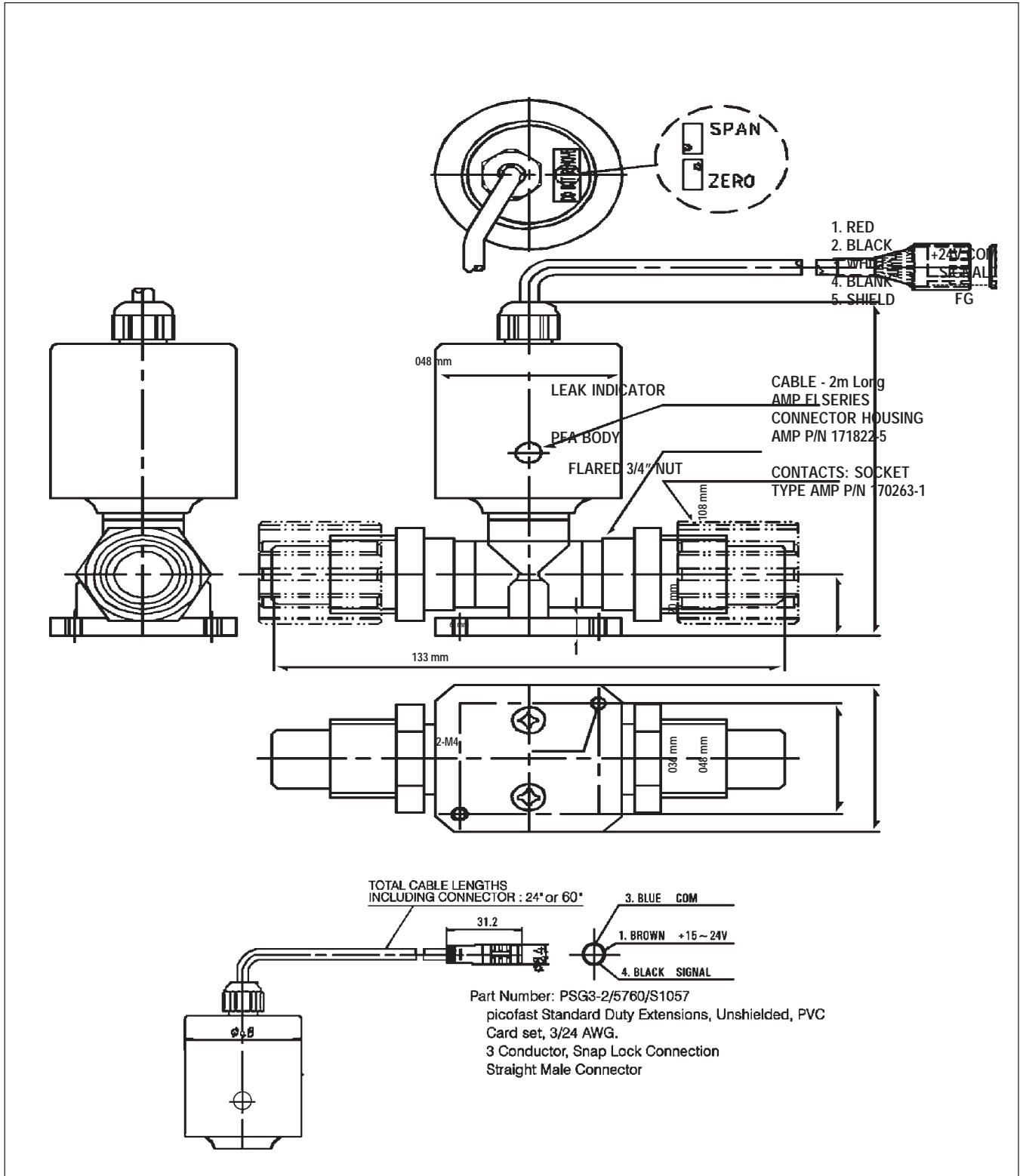

Figure 5 Dimensional Drawing of the Brooks® Model SFP33, Flow-Through Pressure Transmitter with 3/4" Flare Process Connection. The AMP and Turck Electrical Connector Options are Shown.

Table 1 Brooks® Models SFP32 and SFP33 Ordering Information

Model: BROOKS SFP, SEAL FREE PRESSURE MEASUREMENT	
A NON-METALLIC PLASTIC SENSOR FOR ULTRAPURE FLUID SERVICE	
BASE MODEL NUMBER	DESCRIPTION
SFP33WA	FLOW-THROUGH PRESSURE TRANSMITTER FOR ULTRAPURE WATER
SFP33CA	FLOW-THROUGH PRESSURE TRANSMITTER FOR CHEMICALS, ACIDS AND BASES
SFP32WA	SINGLE-ENDED PRESSURE TRANSMITTER FOR ULTRAPURE WATER
SFP32CA	SINGLE-ENDED PRESSURE TRANSMITTER FOR CHEMICALS, ACIDS AND BASES
ABSOLUTE OR GAUGE MEASUREMENT	
1	GAUGE PRESSURE (REFERENCED TO ATMOSPHERIC PRESSURE)
2	ABSOLUTE PRESSURE (REFERENCED TO VACUUM)
MEASURED PRESSURE RANGE	
A	0 - 150 PSI NOTE: ONLY AVAILABLE IN WA MODELS
B	0 - 145 PSI NOTE: ONLY AVAILABLE IN WA MODELS
C	0 - 100 PSI
D	0 - 95 PSI
E	0 - 60 PSI
F	0 - 30 PSI
E	0 - 15 PSI
X	CUSTOM (Consult Factory)
OUTPUT SIGNAL	
1	4 - 20 Ma
2	1 - 5 VDC
3	0 - 5 VDC
4	0 - 10 VDC
PROCESS CONNECTION(S)	
A	1/4" - OD TUBE STUB
B	3/8"- OD TUBE STUB
C	1/2" - OD TUBE STUB
D	1/4" - MALE FLARE TUBE
E	3/8" - MALE FLARE TUBE
F	1/2" - MALE FLARE TUBE
G	3/4" - MALE FLARE TUBE (ONLY AVAILABLE ON SFP33UPW MODEL)
H	1/4" - MALE NPT THREADED (ONLY AVAILABLE ON SFP32UPW MODEL)
J	1/2" - MALE NPT THREADED (ONLY AVAILABLE ON SFP32UPW MODEL)
K	1" - MALE FLARE TUBE (ONLY AVAILABLE ON SFP33UPW MODEL)
L	1/4" - FEMALE NPT THREADED (ONLY AVAILABLE ON SFP 32UPW MODEL)
M	3/8" - FEMALE NPT THREADED (ONLY AVAILABLE ON SFP 32UPW MODEL)
L	1/2" - FEMALE NPT THREADED (ONLY AVAILABLE ON SFP 32UPW MODEL)
WIRING	
1	2 METER PIGTAIL (STANDARD)
2	4 METER PIGTAIL
3	10 METER PIGTAIL
4	2 METER CABLE WITH 5 PIN FEMALE CONNECTOR FOR DISPLAY/ALARM MODULE*
5	POLYPROPYLENE 3 PIN MALE CONNECTOR
6	TURCK CONNECTOR WITH 24 INCH CABLE
7	TURCK CONNECTOR WITH 60 INCH CABLE
Model Code Example: SFP33UPW1B2G4	

*Display/Alarm Module only available for UPW range 0-145 psig with 1-5 VDC output

Brooks® SFP

BROOKS SERVICE AND SUPPORT

Brooks is committed to assuring all of our customers receive the ideal flow solution for their application, along with outstanding service and support to back it up. We operate first class repair facilities located around the world to provide rapid response and support. Each location utilizes primary standard calibration equipment to ensure accuracy and reliability for repairs and recalibration. The primary standard calibration equipment to calibrate our flow products is certified by our local Weights and Measures Authorities and traceable to the relevant International Standards.

Visit www.BrooksInstrument.com to locate the service location nearest to you.

START-UP SERVICE AND IN-SITU CALIBRATION

Brooks Instrument can provide start-up service prior to operation when required. For some process applications, where ISO-9001 Quality Certification is important, it is mandatory to verify and/or (re)calibrate the products periodically. In many cases this service can be provided under in-situ conditions, and the results will be traceable to the relevant international quality standards.

CUSTOMER SEMINARS AND TRAINING

Brooks Instrument can provide customer seminars and dedicated training to engineers, end users and maintenance persons. Please contact your nearest sales representative for more details.

HELP DESK

In case you need technical assistance:

Americas ☎ 1-888-554-FLOW
Europe ☎ +(31) 318 549 290 Within Netherlands ☎ 0318 549 290
Asia ☎ +011-81-3-5633-7100

Due to Brooks Instrument's commitment to continuous improvement of our products, all specifications are subject to change without notice.



TRADEMARKS

Brooks Brooks Instrument, LLC
HART HART Communications Foundation

Brooks Instrument
407 West Vine Street
P.O. Box 903
Hatfield, PA 19440-0903 USA
T (215) 362-3700
F (215) 362-3745
E-Mail BrooksAm@BrooksInstrument.com
www.BrooksInstrument.com

Brooks Instrument
Neonstraat 3
6718 WX Ede, Netherlands
T 31-318-549-300
F 31-318-549-309
E-Mail BrooksEu@BrooksInstrument.com

Brooks Instrument
1-4-4 Kitasuna Koto-Ku
Tokyo, 136-0073 Japan
T 011-81-3-5633-7100
F 011-81-3-5633-7101
E-Mail BrooksAs@BrooksInstrument.com

