

Brooks® Flomega™, Liquid MFC's/MFM's Models 5881/91 and 5882/92

- Very low liquid flow from 1 to 1000 grams/hour
- Unique thru-flow patented sensor and in-line valve design
- Assured process accuracy and repeatability
- Long-term reliability, CE certified
- Reduced maintenance
- Improved safety
- Designed, developed, manufactured and supplied by the first ISO-9001 Quality Certified M&C company in the world: Brooks Instrument

DESCRIPTION

The patented Flomega thru-flow liquid mass flow meter design is the heart of the system. All models are self-contained with signal conditioning electronics and housed in weather-proof IP-65 certified enclosures. In addition the Flomega liquid controller also includes an integrally mounted control valve and -controller electronics.

FEATURES

- Continuous mass flow measurement and control for difficult low liquid flow ranges
- Superior thru-flow design mass flow sensor
- Enhanced performance
- High accuracy and repeatability
- Stand-alone modular design
- Jumper selectable input/output signal configuration
- Closed system



Model 5881, Flomega, Mass Flow Controller for Liquid Flow Applications

BENEFITS

- Eliminates the necessity to batch processing higher productivity / Lower Costs
- Virtually insensitive to process temperature, pressure, density or viscosity changes (specific heat value dependent)
- High reliability ensures proper process recipe
- Verify and calibrate other instruments and provides consistent process results
- Packaged in rugged enclosure insensitive to mounting position
- Easy installation
- Safe with toxic and volatile liquids
- Can be used in many industrial applications
- Applicable to food and pharmaceutical applications where sterilization is important)

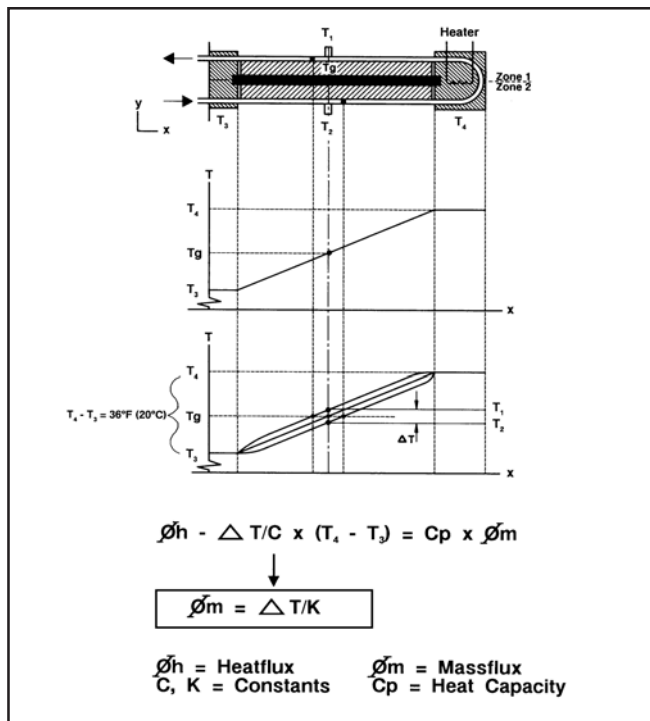

Figure 1 Thermodynamic Measurement Principle

PROVEN SENSOR AND CONTROLLER TECHNOLOGY

Flomega is based on a proven thermodynamic measurement principle. Brooks Instrument developed a thru-flow (no bypass) mass flow meter especially for low-flow liquid applications. In this meter, (see Figure 1) the heat is transferred perpendicular to the fluid flow. The temperature difference T1-T2 reflects the heat current and is proportional to the liquid flow. The result is a linear and fast responding mass flow meter.

The Flomega liquid mass flow controller consists of the same unique meter design, an in-line control valve and control electronics (see Figure 2). This stand alone unit is capable in accurately controlling low liquid flows. The in-line valve has been designed to reduce dead volume as much as possible, to ensure trouble-free operation. It avoids gas being trapped in the valve construction and improves the ability to purge.

EASE OF INSTALLATION

The Flomega liquid mass flow meter and liquid mass flow controller are mounted in rugged -enclosures suitable for operation in harsh conditions. All models are stand-alone instruments and are easy to service and can be installed in any mounting -position. Please refer to the installation and operating manual for details. Fittings are available for connection to different line sizes.

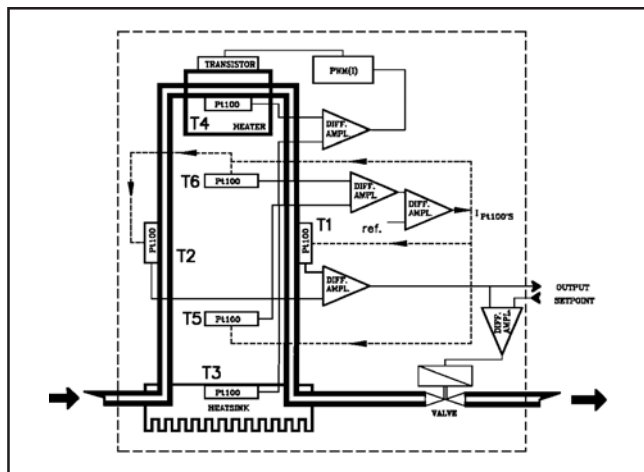

Figure 2 Principle of Mass Flow Controller

EASE OF OPERATION

Because of the unique sensor and valve design manual degassing during operation is not needed. In order to release the entrained gas in the valve compartment during start-up the Flomega electronics has been equipped with a valve override purge option, which removes gas very quickly. A vertical-upward position of the Flomega is also beneficial for this reason. No special precautions during operation are needed.

Reconfiguring the valve to new process conditions is hardly required, because the Flomega can be applied over a large range of process conditions. When needed, tuning the control valve is a simple task. For ease of maintenance, the orifice can be adjusted in the field. The adjustment can be performed without disassembling the unit.

PERFORMANCE SPECIFICATIONS

- Accuracy incl. linearity: ±0.5% full scale measured at calibration conditions
- Process temperature effects: ±0.03% F.S./°C
- Ambient temperature effects: ±0.1 % F.S./°C

Repeatability

Applicable Flow Range		
Models	From 100% to 50% of Max. F.S.	Less than 50% of Max. F.S.
5881/91	±0.2% of rate	±0.2% of F.S.*
5882/92	±0.2% of rate	±0.4% of rate

* The measurement repeatability is (technically) limited by the current calibration using a highly accurate balance (weighscale)

Flow Ranges

Brooks Flomega™			PED Mod. Category
Models	Min. F.S. flow rate*	Max. F.S. flow rate*	
5881/91	15 gr/h**	100 gr/h**	SEP
5882/92	200 gr/h	1000 gr/h**	SEP

* To be specified at ordering (factory selectable) (water equivalent flow ranges)
** Down to 15 gr/hour minimum full scale is possible @ ±1% f.s. accuracy and ±0.4% f.s. repeatability flow ranges from > 30 gr/h are within specified accuracy

Rangeability: 50:1
Viscosity Limits: Up to 200cP (limited by max. diff.pressure)
Ambient Temperature Range: 0-65°C
Process Temperature Range: 0-100°C (Model 5882/92: max. 90°C)

Pressure Equipment Directive (PED) 97/23/EC

Pressure Limits: 100/400 bar versions
Max. Press. Difference:
•Model 5881: 20 bar
•Model 5882: 40 bar
Pressure Drop Sensor:
•Model 5891: 10 mbar @ 100 gram/hour water
•Model 5892: 150 mbar @ 1000 gram/hour water

Setpoint Input/
Flow Signal Out: 0 (4)-20 mA*, or 0-5 Vdc*

Power Supply: +15 Vdc or 24 Vdc* ±10% max. current 660 mA
Warm-Up Time: Performance within specifications: 60 minutes (Within +1.5% F.S. accuracy: 15 minutes)

Response Time: (To within 2% of final value for a 2-100% command change, at a constant operating pressure)
•Model 5881/91: 5 seconds
•Model 5882/92: 7 seconds

Mounting Insensitivity: Not affected by mounting position*

Certification: CE certified
Protection Grade: IP65 weather proof

* To be specified at ordering

PHYSICAL SPECIFICATIONS

Mechanical Connections
•Standard: 5/16", 1/16" or 1/8" Tube Connections
•Optional: 1/4" tube compression, 1/4" NPT (F), 1/4" VCO®, 1/4" VCR®
Inlet Filter
Material: stainless steel
Mesh size: 40 micron
Materials of Construction
•All wetted materials: stainless steel.
Seals: Viton®fluoroelastomer, PTFE, EPDM, Buna, Kalrez® or Teflon®
Housing Materials
Cast aluminum
Electrical Connections
12-pole circular connector
Weight
Less than 3.5 kg

Dimensions (See Figure 3)

Refer to Brooks Installation and Operation manual X-TMF-FM-MFC-eng for installation guidelines.

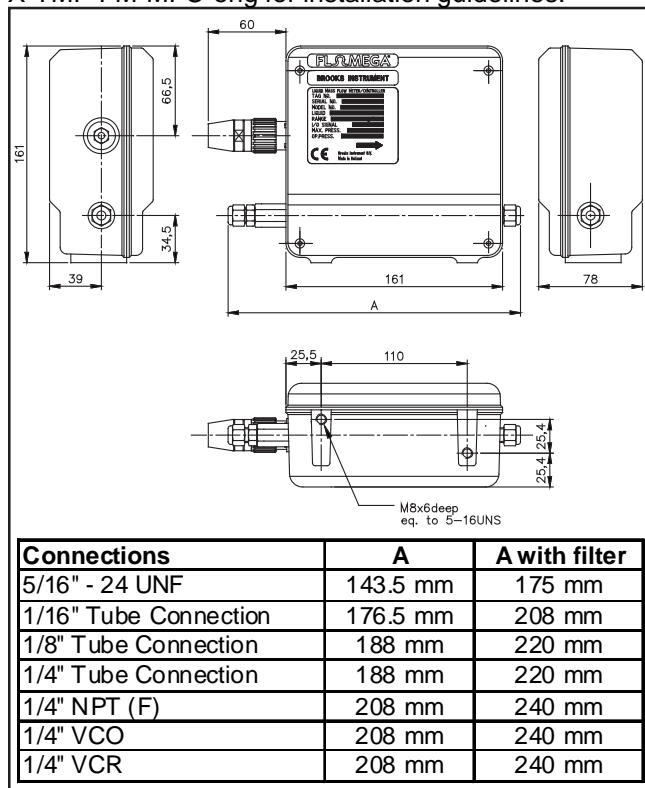

Figure 3 Flomega Dimensions

BROOKS SERVICE AND SUPPORT

Brooks is committed to assuring all of our customers receive the ideal flow solution for their application, along with outstanding service and support to back it up. We operate first class repair facilities located around the world to provide rapid response and support. Each location utilizes primary standard calibration equipment to ensure accuracy and reliability for repairs and recalibration. The primary standard calibration equipment to calibrate our flow products is certified by our local Weights and Measures Authorities and traceable to the relevant International Standards.

Visit www.BrooksInstrument.com to locate the service location nearest to you.

START-UP SERVICE AND IN-SITU CALIBRATION



Brooks Instrument can provide start-up service prior to operation when required. For some process applications, where ISO-9001 Quality Certification is important, it is mandatory to verify and/or (re)calibrate the products periodically. In many cases this service can be provided under in-situ conditions, and the results will be traceable to the relevant international quality standards.

CUSTOMER SEMINARS AND TRAINING

Brooks Instrument can provide customer seminars and dedicated training to engineers, end users and maintenance persons. Please contact your nearest sales representative for more details.

HELP DESK

In case you need technical assistance:

Americas		1 888 554 FLOW
Europe		+31 (0) 318 549 290
Asia		+81 (0) 3 5633 7100

Due to Brooks Instrument's commitment to continuous improvement of our products, all specifications are subject to change without notice.

TRADEMARKS

Brooks	Brooks Instrument, LLC
Flomega	Brooks Instrument, LLC
Kalrez	DuPont Dow Elastomers
Teflon	E.I. DuPont de Numours & Co.
VCO, VCR	Swagelok Co.
Viton	DuPont Performance Elastomers.



Brooks Instrument
407 West Vine Street
P.O. Box 903
Hatfield, PA 19440-0903 USA
T (215) 362 3700
F (215) 362 3745
E-Mail BrooksAm@BrooksInstrument.com
www.BrooksInstrument.com

Brooks Instrument
Neonstraat 3
6718 WX Ede, Netherlands
T +31 (0) 318 549 300
F +31 (0) 318 549 309
E-Mail BrooksEu@BrooksInstrument.com

Brooks Instrument
1-4-4 Kitasuna Koto-Ku
Tokyo, 136-0073 Japan
T +81 (0) 3 5633 7100
F +81 (0) 3 5633 7101
E-Mail BrooksAs@BrooksInstrument.com