

Brooks® IPT122 2 Inch Indicating Pressure Transmitter



*IPT122
2 Inch Indicating Pressure
Transmitter*

Essential Instructions

Read this page before proceeding!

Brooks Instrument designs, manufactures and tests its products to meet many national and international standards. Because these instruments are sophisticated technical products, you must properly install, use and maintain them to ensure they continue to operate within their normal specifications. The following instructions must be adhered to and integrated into your safety program when installing, using and maintaining Brooks Products.

- Read all instructions prior to installing, operating and servicing the product. If this instruction manual is not the correct manual, please see back cover for local sales office contact information. Save this instruction manual for future reference.
- If you do not understand any of the instructions, contact your Brooks Instrument representative for clarification.
- Follow all warnings, cautions and instructions marked on and supplied with the product.
- Inform and educate your personnel in the proper installation, operation and maintenance of the product.
- Install your equipment as specified in the installation instructions of the appropriate instruction manual and per applicable local and national codes. Connect all products to the proper electrical and pressure sources.
- To ensure proper performance, use qualified personnel to install, operate, update, program and maintain the product.
- When replacement parts are required, ensure that qualified people use replacement parts specified by Brooks Instrument. Unauthorized parts and procedures can affect the product's performance and place the safe operation of your process at risk. Look-alike substitutions may result in fire, electrical hazards or improper operation.
- Ensure that all equipment doors are closed and protective covers are in place, except when maintenance is being performed by qualified persons, to prevent electrical shock and personal injury.

Pressure Equipment Directive (PED)

All pressure equipment with an internal pressure greater than 0.5 bar (g) and a size larger than 25mm or 1" (inch) falls under the Pressure Equipment Directive (PED). The Directive is applicable within the European Economic Area (EU plus Norway, Iceland and Liechtenstein). Pressure equipment can be traded freely within this area once the PED has been complied with.

- Section 1 of this manual contains important safety and operating instructions related to the PED directive.
- Meters described in this manual are in compliance with EN directive 97/23/EC module H *Conformity Assessment*.
- All Brooks Instrument Flowmeters fall under fluid group 1.
- Meters larger than 25mm or 1" (inch) are in compliance with category I, II, III of PED.
- Meters of 25mm or 1" (inch) or smaller are Sound Engineering Practice (SEP).

ESD (Electrostatic Discharge)

CAUTION

This instrument contains electronic components that are susceptible to damage by static electricity. Proper handling procedures must be observed during the removal, installation or other handling of circuit boards or devices.

Handling Procedure:

1. Power to unit must be removed.
2. Personnel must be grounded, via a wrist strap or other safe, suitable means before any printed circuit card or other internal device is installed, removed or adjusted.
3. Printed circuit cards must be transported in a conductive container. Boards must not be removed from protective enclosure until immediately before installation. Removed boards must immediately be placed in protective container for transport, storage or return to factory.

Comments

This instrument is not unique in its content of ESD (electrostatic discharge) sensitive components. Most modern electronic designs contain components that utilize metal oxide technology (NMOS, SMOS, etc.). Experience has proven that even small amounts of static electricity can damage or destroy these devices. Damaged components, even though they appear to function properly, exhibit early failure.

Installation and Operation Manual

X-PR-IPT122-eng

Part Number: 541B151AAG

April, 2010

IPT122 Series

Dear Customer,

We appreciate this opportunity to service your pressure measurement and control requirements with a Brooks Instrument device. Every day, customers all over the world turn to Brooks Instrument for solutions to their gas and liquid control applications. Brooks provides an array of flow pressure and level measurement and control products for various industries from biopharmaceuticals, oil and gas, fuel cell research and chemicals, to medical devices, analytical instrumentation, semiconductor manufacturing, and more.

The Brooks product you have just received is of the highest quality available, offering superior performance, reliability and value to the user. It is designed with the ever changing process conditions, accuracy requirements and hostile process environments in mind to provide you with a lifetime of dependable service.

We recommend that you read this manual in its entirety. Should you require any additional information concerning Brooks products and services, please contact your local Brooks Sales and Service Office listed on the back cover of this manual or visit www.BrooksInstrument.com.

Yours sincerely,

Brooks Instrument

*THIS PAGE WAS
INTENTIONALLY
LEFT BLANK*

<u>Paragraph Number</u>		<u>Page Number</u>
Section 1 Introduction		
1-1	Function/Operation	1-1
1-2	Specifications	1-2
1-3	IPT122 Series Dimensional Drawings	1-3
Section 2 Installation		
2-1	General	2-1
2-2	Receipt of Equipment	2-1
2-3	Recommended Storage Practice	2-1
2-4	Return Shipment	2-2
2-5	Transit Precautions	2-2
2-6	Removal from Storage	2-2
2-7	Gas Connections	2-2
2-8	IPT122 Series Indicating Pressure Transmitter Mechanical Installation	2-3
2-9	IPT122 Series Electrical Installation	2-4
Section 3 Calibration		
3-1	Gauge Adjustment	3-1
3-2	Adjustments and Calibration	3-1
3-2-1	ZERO Adjustment Potentiometer	3-1
3-2-2	SPAN Adjustment Potentiometer	3-1
3-3	IPT122 Series Inside Views	3-2
Section 4 Maintenance		
4-1	Introduction	4-1
4-2	Disassembly	4-2
4-3	Reassembly	4-3
Warranty, Local Sales/Service Contact Information		Back Cover

Figures

<u>Figure Number</u>		<u>Page Number</u>
1-1	IPT122 Dimensions	1-3
2-1	IPT122 Bottom and Side Views	2-4
2-2	IPT122 Electrical Connections for Types 1, 2, 3 and 4	2-5
2-3	IPT122 Electrical Connections for Types 5, 6, 8 and 9	2-6
3-1	IPT122 Inside Views Types 1 through 9	3-2
4-1	Typical Assembly/Disassembly	4-2

*THIS PAGE WAS
INTENTIONALLY
LEFT BLANK*

1-1 Function/Operation

The Brooks Instrument IPT122 Series, 2 inch Indicating Pressure Transmitter (IPT) is a very versatile sending unit that can be used for semiconductor processing, including, but not limited to bulk gas, gas cabinets, gas distribution, and gas panels. Accurate within 1% of full scale, the IPT can provide selected outputs with pressure ranges up to 4,000 psi. The IPT is designed with 0 - 5 VDC, 1 - 5 VDC, or 4 - 20 mA outputs.

This manual is organized into the following sections:

Section 1 - Introduction

Section 2 - Installation

Section 3 - Calibration

Section 4 - Maintenance

Back Cover - Limited Warranty and Contacts

It is recommended that this manual be read in its entirety before attempting to operate or repair the Model IPT122 Series.

IPT122 Series

1-2 Specifications

⚠ WARNING

Do not operate this instrument in excess of the specifications listed below. Failure to heed this warning can result in serious personal injury and/or damage to the equipment.

⚠ CAUTION

It is the user's responsibility to select and approve all materials of construction. Careful attention to metallurgy, engineered materials and elastomeric materials is critical to safe operation.

	Type 1	Type 2	Type 3	Type 4	Type 5	Type 6	Type 8	Type 9	
Electrical									
Output Signal	0-5 Vdc Differential	1-5 Vdc Differential	0-5 Vdc Ground Referenced	4-20 mA Current Sink	0-5 Vdc, 1-5 Vdc, 4-20 mA Current Sink	4-20 mA Current Sink 1-5 Vdc Ground Referenced Output		4-20 mA Current Source	
Voltage In	11.5 to 30 Vdc (12 Volts Recommended)								
Voltage Stability	Filtered power supply with noise < 2 mV RMS, ripple < 6 mV P-P								
Operating Current (Exclusive of Signal)	20 mA								
Operating Current (Voltage Signals)	8 mA continuous, 10 mA maximum intermittent								
Current Signals	Currents are limited to 60 mA (Max.)								
Connections									
Electrical Transmitter Leads	6' Cable, Tinned Ends						3 Pin Molex Connector w/ 10' Cable	6' Cable, Tinned Ends	
Physical	Face-seal male, face-seal swivel male, face-seal swivel female and 1/4" NPT male								
Performance									
Accuracy	1% of Full Scale								
Helium Leak Check	4 x 10 ⁻⁹ Inboard Std. cc/sec								
Response Time	Less than 200 milliseconds								
Temperature	Operating (ambient): 0° to 160°F (-18° to 71°C) Compensating: 20° to 135°F (-7° to 57°C) Storage: -20° to 175°F (-29° to 79°C)								
Proof Pressure	110% of Full Scale								
Burst Pressure	400% of Full Scale								
Materials									
Case material	300 Series Stainless Steel								
Bezel and Lens Material	One-piece polycarbonate, Screw-on								
Socket and Bourdon Tube	316L Stainless Steel								
Movement	300 Stainless Steel								
Dial	White with black marking "Use No Oil" is red								

1-3 IPT122 Series Dimensional Drawings

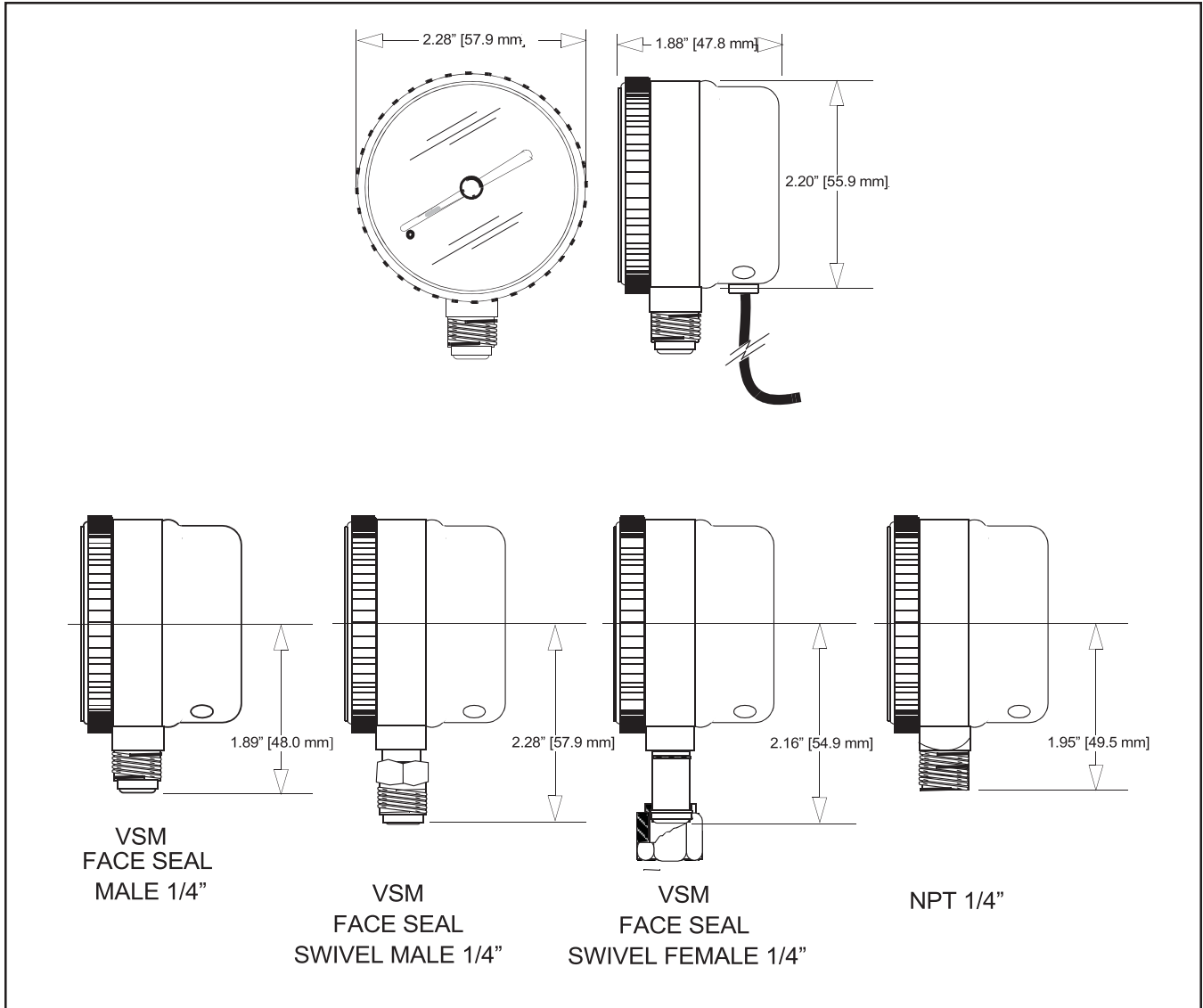

Figure 1-1 IPT122 Dimensions

*THIS PAGE WAS
INTENTIONALLY
LEFT BLANK*

2-1 General

This section provides installation instructions for the Brooks® IPT122 Series Indicating Pressure Switch devices. Refer to Section 1 of this manual for the dimensions and process connections.

Prepare the pressure transmitter for use.

Verify integrity of the seal by appropriate helium leak-testing procedures. Turn the gas flow ON then OFF, 10 times to remove any particles generated during installation. (The flow rate used should at least equal the process flow specifications.)

Mechanical Installation is complete. Complete electrical connections as noted in the next section.

2-2 Receipt of Equipment

When the instrument is received, the outside packing case should be checked for damage incurred during shipment. If the packing case is damaged, the local carrier should be notified at once regarding his liability. A report should be submitted to your nearest Product Service Department.

Brooks Instrument

407 W. Vine Street
P.O. Box 903
Hatfield, PA 19440 USA
Toll Free (888) 554 FLOW (3569)
Tel (215) 362 3700
Fax (215) 362 3745
E-mail: BrooksAm@BrooksInstrument.com
www.BrooksInstrument.com

Brooks Instrument

Neonstraat 3
6718 WX Ede, Netherlands
P.O. Box 428
6710 BK Ede, Netherlands
Tel +31 (0) 318 549 300
Fax +31 (0) 318 549 309
E-mail: BrooksEu@BrooksInstrument.com

Brooks Instrument

1-4-4 Kitasuna Koto-Ku
Tokyo, 136-0073 Japan
Tel +81 (0) 3 5633 7100
Fax +81 (0) 3 5633 7101
Email: BrooksAs@BrooksInstrument.com

Remove the envelope containing the packing list. Carefully remove the instrument from the packing case. Make sure spare parts are not discarded with the packing materials. Inspect for damaged or missing parts.

2-3 Recommended Storage Practice

If intermediate or long-term storage of equipment is required, it is recommended that the equipment be stored in accordance with the following:

- a. Within the original shipping container.
- b. Ambient temperature 21°C (70°F) nominal, 79°C (175°F) maximum -29°C (-20°F) minimum.
- c. Relative humidity 45% nominal, 60% maximum, 25% minimum.

IPT122 Series

2-4 Return Shipment

Prior to returning any device to the factory, visit the Brooks web site (www.BrooksInstrument.com) for a Return Materials Authorization Number (RMA#), or contact one of the locations provided on p. 2-1.

Prior to returning the device, it must be purged in accordance with the following:

⚠ WARNING

Before returning the device purge thoroughly with a dry inert gas such as Nitrogen before disconnecting gas connections. Failure to correctly purge the instrument could result in fire, explosion or death. Corrosion or contamination may occur upon exposure to air.

All devices returned to Brooks require completion of Form RPR003-1, Brooks Instrument Decontamination Statement, along with a Material Safety Data Sheet (MSDS) for the fluid(s) used in the instrument. Failure to provide this information will delay processing by Brooks personnel. Copies of these forms can be downloaded from the Brooks website (www.BrooksInstrument.com) or are available from any of the Brooks Instrument locations provided on p. 2-1.

2-5 Transit Precautions

To safeguard against damage during transit, transport the device to the installation site in the same container used for transportation from the factory, if circumstances permit.

2-6 Removal from Storage

Upon removal of the device from storage, a visual inspection should be conducted to verify its "as-received" condition. If the device has been subject to storage conditions in excess of those recommended (refer to Section 2-3 "Recommended Storage Practice" on p. 2-1), it should be subjected to a pneumatic pressure test in accordance with applicable vessel codes.

2-7 Gas Connections

Prior to installation, ensure that all piping is clean and free from obstructions. Install piping in such a manner that permits easy access to the device if removal becomes necessary.

2-8 IPT122 Indicating Pressure Transmitter Mechanical Installation

⚠ CAUTION

Perform all operations with standard gas handling procedures in accordance with all local codes for safety and ventilation. You MUST wear appropriate clothing and safety apparatus for the gas you are using.

Failure to follow these procedures may adversely affect the product's performance and could void the product warranty. Inspect but DO NOT unwrap any parts until installation. Contact your Brooks representative with any problems.

1. Unpack the pressure transmitter

Determine that the desired IPT unit is listed on the packaging. Do not open if the package does not contain the proper device.

The IPT is double-bagged for cleanroom service and should remain packaged until installation.

Do not remove the pressure transmitter from the protective bag unless you are in a clean environment.

- A. Remove pressure transmitter from the box and carry it into the gray area.
- B. Remove and discard the outer protective bag.
- C. Carry the pressure transmitter (sealed in the inner bag) into the clean area.

2. Install the pressure transmitter

- A. Prepare the connection fitting in place on the gas line. Any other fitting components, such as stainless steel gaskets, should be blown clean with a filtered gas before use.
- B. Note: For installation in tight spaces, and on some regulators, it may be necessary to remove the electronic assembly (back half) of the IPT. This reduces the depth of the gauge by approximately 7/16".
- C. Maintain a flow of at least 1 slpm (0.05 scfm) of inert gas during installation to minimize tubing and IPT contamination from environmental moisture and particles. The recommended purge gas is electronic-grade Nitrogen.
- D. Open the inner bag and remove the pressure transmitter. Remove any fitting protection caps and seat the pressure transmitter on the mating connections.
- E. Tighten the nuts by hand, then 1/8 turn past hand-tight by wrench for fittings compatible with VCR® fittings. DO NOT overtighten.

Note: Refer to specific technical guides furnished by fitting manufacturers for additional specifications.

IPT122 Series

3. Prepare the pressure transmitter for use
 - A. Verify integrity of the seal by appropriate helium leak-testing procedures.
 - B. Turn the gas flow ON then OFF, 10 times to remove any particles generated during installation. (The flow rate used should at least equal the process flow specifications.)
 - C. Mechanical Installation is complete. Complete electrical connections as noted in the next section.

2-9 IPT122 Electrical Installation

Refer to Figures 2-1 through 2-3 for electrical connections.

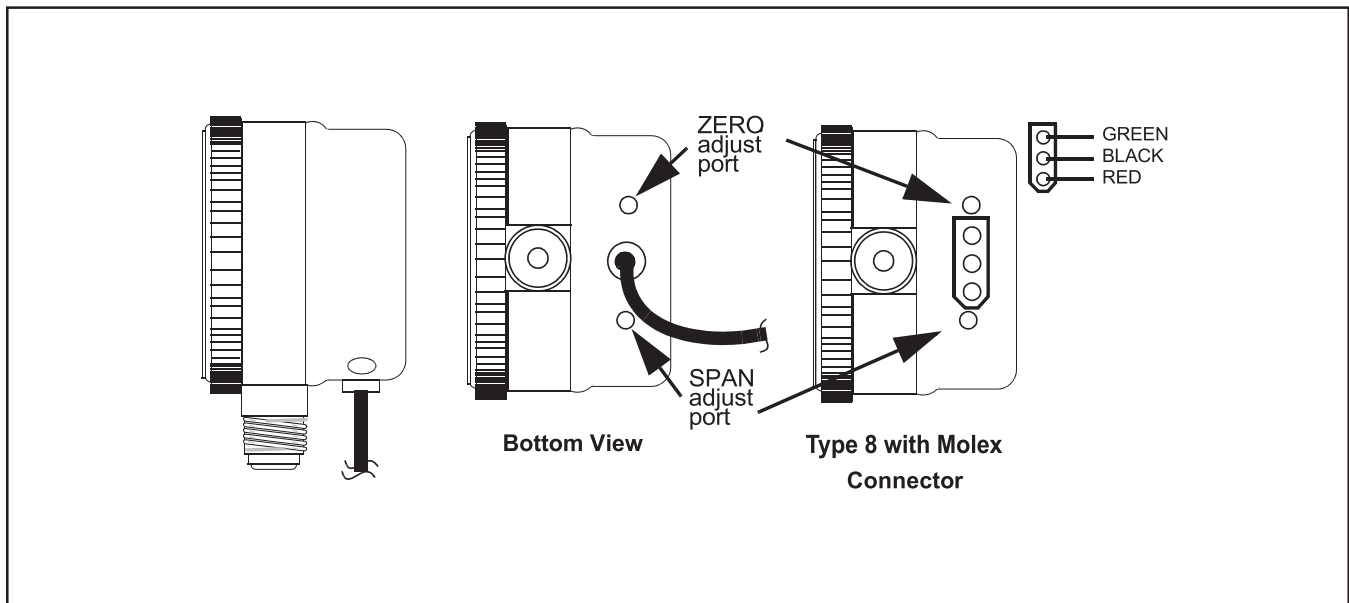
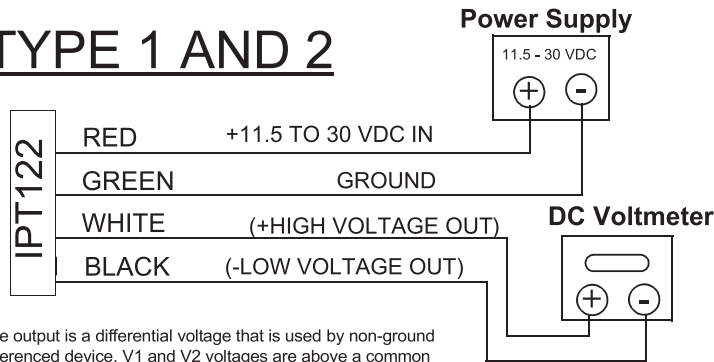

Figure 2-1 IPT122 Bottom and Side Views

TYPE 1 AND 2



The output is a differential voltage that is used by non-ground referenced device. V1 and V2 voltages are above a common voltage greater than 1 volt. Connecting V1 to - and V2 to + of a voltmeter reads the voltage V2 minus V1. Differential output is used to provide a true zero output at zero pressure. When adjusted so that zero pressure (PSIG) equals zero volts, negative voltage is output if negative pressure is applied to the gauge.



TYPE 3

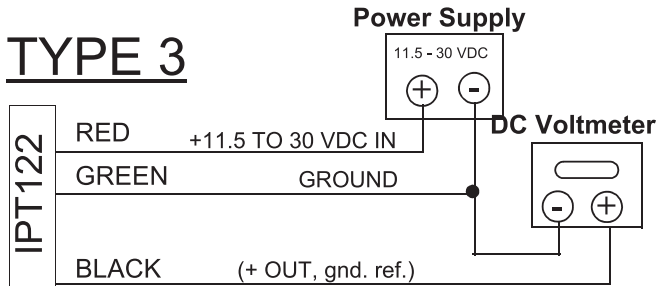

Output is provided as a positive voltage above ground (power supply common). The normal factory calibrated range is +1 to +5 VDC, although it may be adjusted. Adjustment allows the zero pressure output to be set for less than +0.4 VDC to more than +3 VDC.



TYPE 4 One Power Source for Gauge and Current Device

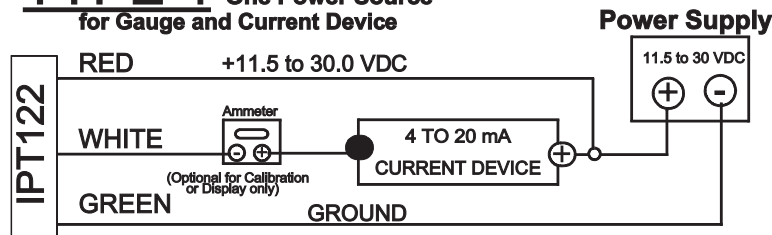

TYPE 4 Two Power Sources for Gauge and Current Device

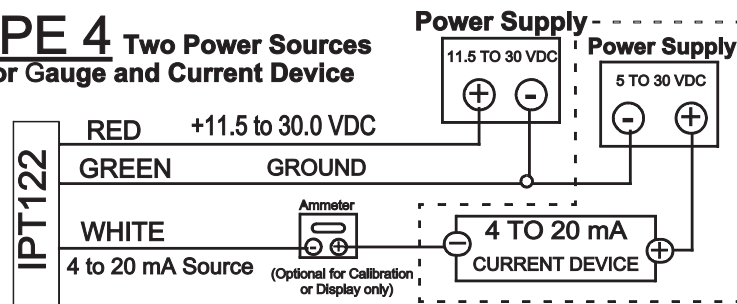

The IPT Type 4 sinks 4-20 mA proportional to pressure and independent of power supply voltage. Voltage input on the WHITE wire must be minimum +5 VDC to maximum +30 VDC. A common ground (GREEN) wire is used for both the power supply to the gauge and the voltage input of the current device.

Figure 2-2 IPT122 Electrical Connections for Types 1, 2, 3 and 4

IPT122 Series

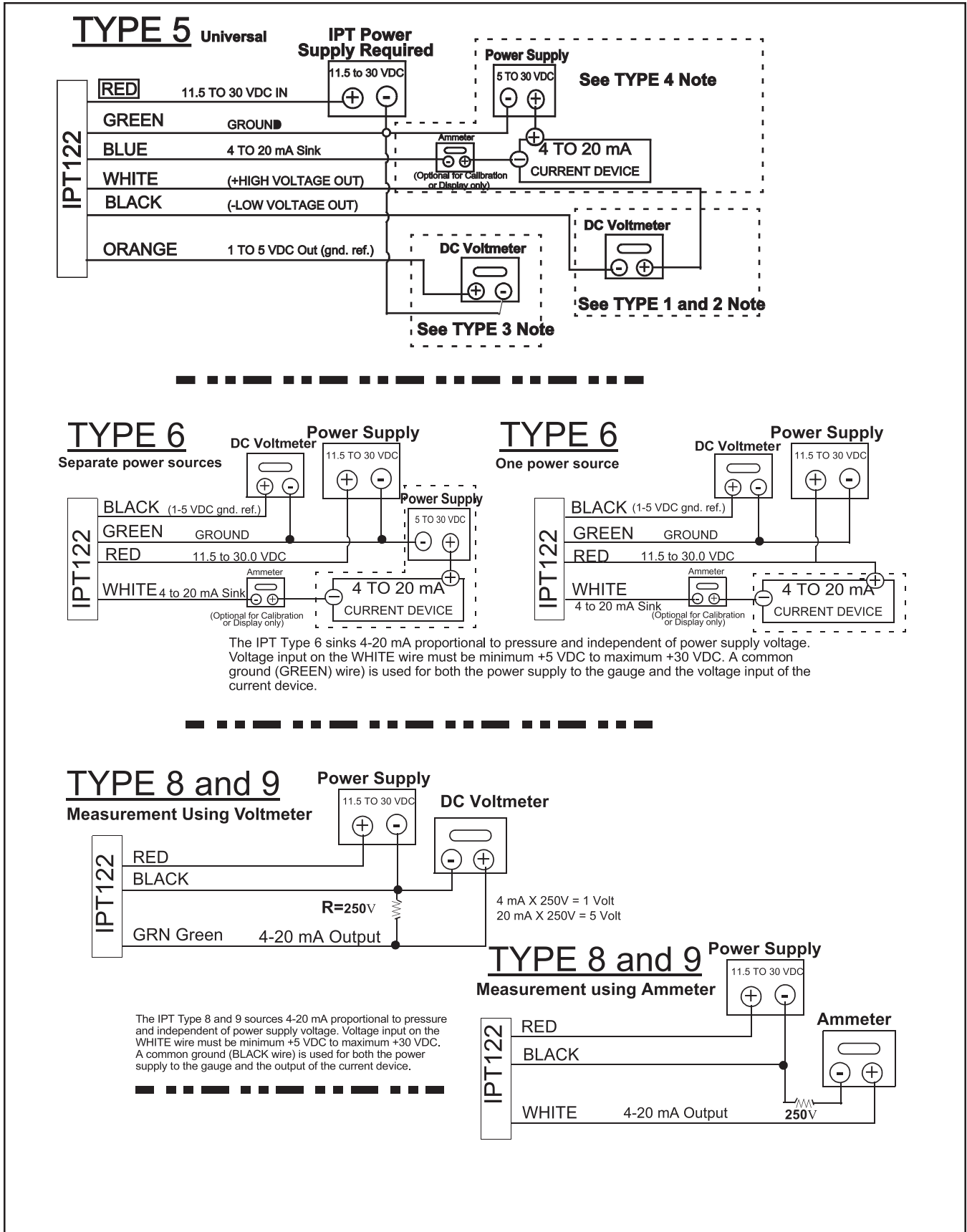

2-6 Figure 2-3 IPT122 Electrical Connections for Types 5, 6, 8 and 9

3-1 Gauge Alignment

Since the IPT122 is an electromechanical device, the gauge linkage may move from the home position during shipment or installation. Pressure cycle the gauge a few times to assure the movement is in its home position.

3-2 Adjustments and Calibration

The IPT122 is factory calibrated for the proper output. Field calibration is only necessary if ZERO and SPAN adjust potentiometers have been changed or different output is required.

3-2-1 ZERO Adjustment Potentiometer

(See Figures 2-1, 3-1 and 4-1)

The IPT122 is factory calibrated for the proper output. Field calibration is only necessary if ZERO and SPAN adjust potentiometers have been changed or different output is required.

3-2-2 SPAN Adjustment Potentiometer

(See Figures 2-1, 3-1 and 4-1)

The SPAN adjustment sets the output signal to the high level when full scale pressure is applied to the gauge Calibration Procedure

1. Turn on power and pressure cycle the IPT a few times to verify a reading at the voltmeter and to assure the mechanical movement is in its home position.
2. Set pressure to zero (remove all pressure).
3. Rotate the ZERO adjust potentiometer CW to increase, or CCW to decrease the output signal. Set the output to the low level (for example, 4 mA).
4. Apply full scale pressure to IPT.
5. Rotate the SPAN adjust potentiometer CW to increase, or CCW to decrease the output signal. Set the output to the high level (for example, 20 mA).
6. Set pressure to zero and repeat the calibration procedure until accuracy of SPAN and ZERO points is obtained.

IPT122 Series

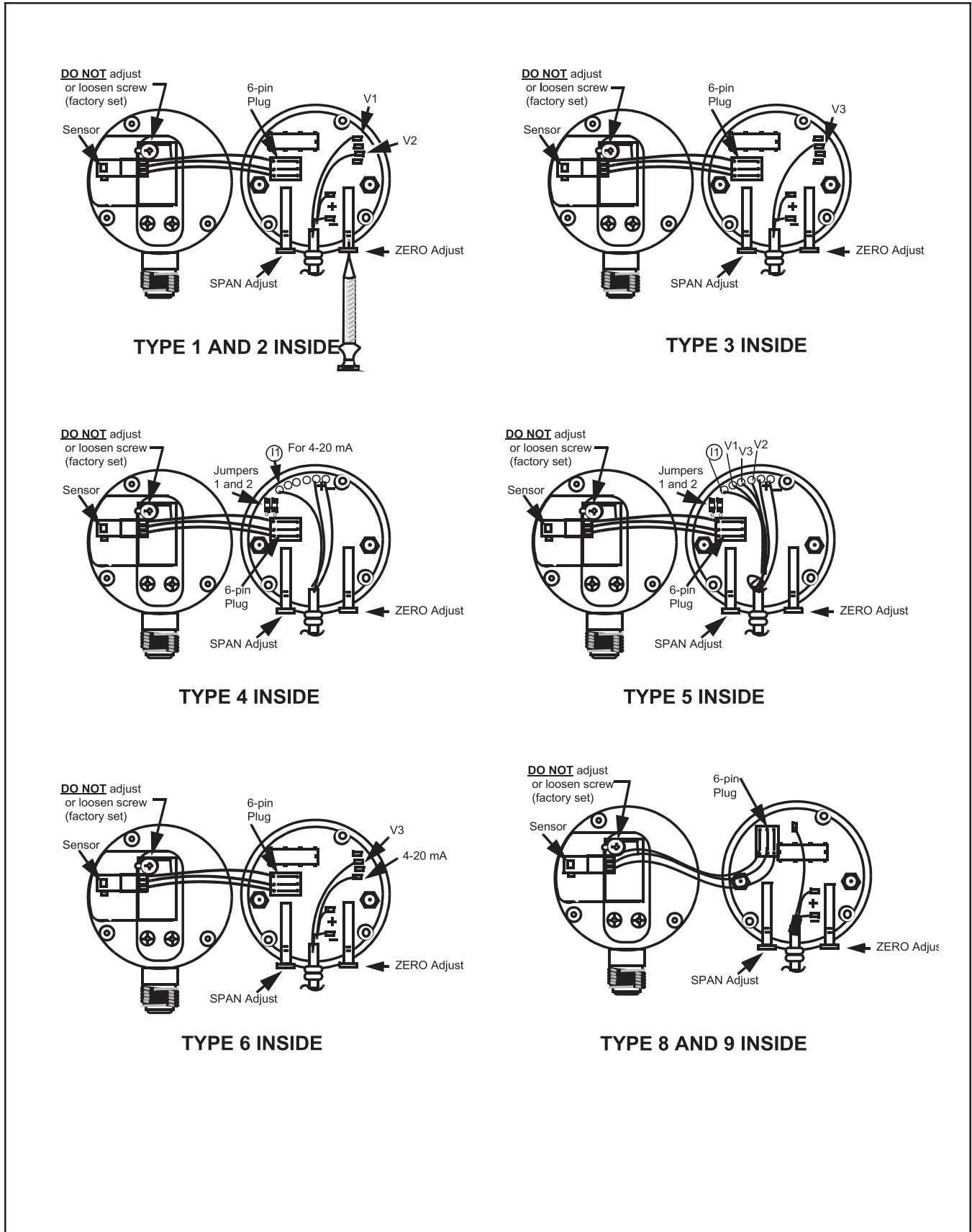

3-2 Figure 3-1 IPT122 Inside Views Types 1 through 9

4-1 Introduction

The IPT122 is designed to operate continuously over long periods of time with no maintenance and no adjustment. Cycle testing of the gauge at annual intervals is recommended to insure smooth operation and to verify the ZERO and SPAN adjustments.

	⚠ WARNING
METER/CONTROLLER SEAL COMPATIBILITY	
<p>Products in this manual may contain metal or elastomeric seals, gaskets, O-rings or valve seats. It is the "user's" responsibility to select materials that are compatible with their process and process conditions. Using materials that are not compatible with the process or process conditions could result in the Meter or Controller leaking process fluid outside the pressure boundary of the device, resulting in personnel injury or death.</p> <p>It is recommended that the user check the Meter or Controller on a regular schedule to ensure that it is leak free as both metal and elastomeric seals, gaskets, O-rings and valve seats may change with age, exposure to process fluid, temperature, and /or pressure.</p>	

⚠ WARNING
If it becomes necessary to remove the device from the system, power to the device must be disconnected.

⚠ WARNING
If it becomes necessary to remove the controller from the system after exposure to toxic, pyrophoric, flammable or corrosive gas, purge the controller thoroughly with a dry inert gas such as Nitrogen before disconnection the gas connections. Failure to correctly purge the controller could result in fire, explosion or death. Corrosion or contamination of the mass flow controller, upon exposure to air, may also occur.

⚠ CAUTION
This instrument contains electronic components that are susceptible to damage by static electricity. Proper handling procedures must be observed during the removal, installation or other handling of internal circuit boards or devices.

IPT122 Series

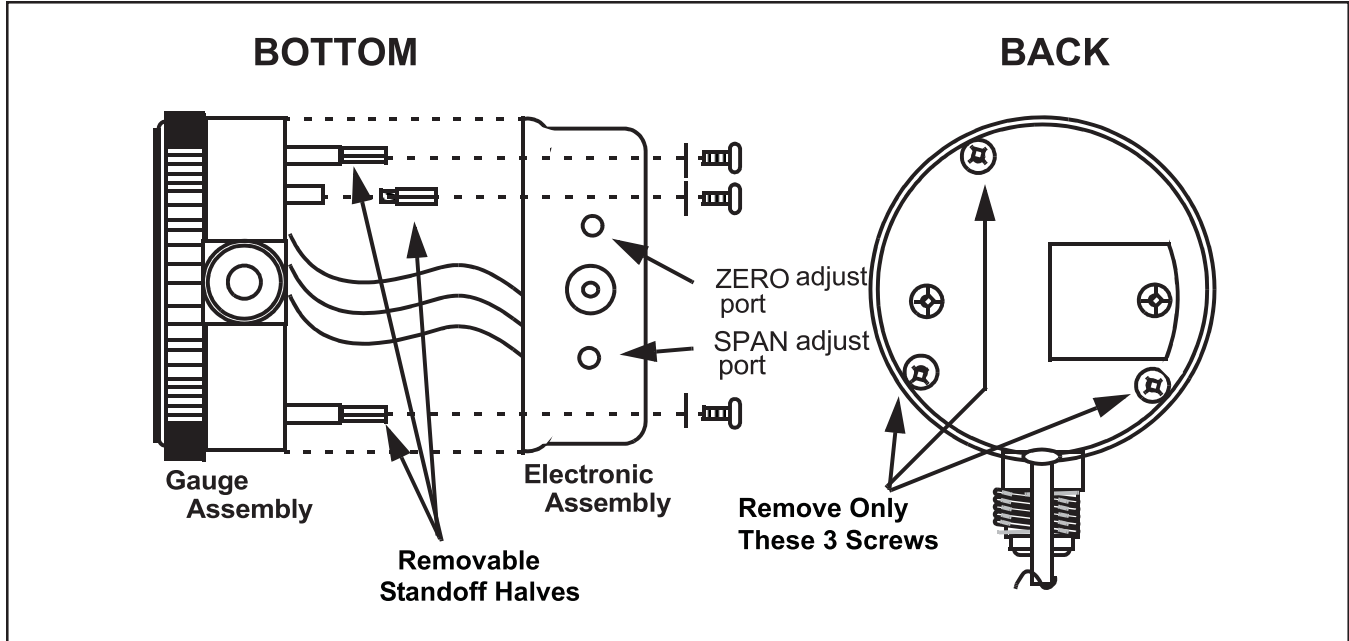

Figure 4-1 Typical Assembly/Disassembly

4-2 Disassembly

CAUTION

DO NOT twist the plug and DO NOT pull by the wires.

Under normal conditions, it will not be necessary to disassemble the IPT. If however disassembly is necessary, use the following steps for disassembling the device:

(See Figure 4-1 Typical Assembly/Disassembly and Figure 3-1 IPT122 Inside Views Types 1 Through 9).

1. Remove three (3) screws on back of gauge and lift electronic assembly straight off.
2. Remove the six-pin sensor plug straight up.
3. Remove three (3) standoff halves.

4-3 Reassembly

CAUTION

Plugging the six-pin plug in backwards will destroy the sensor. DO NOT interchange electronic assemblies between the different gauges (each device is factory matched). DO NOT adjust the sensor mounting, it is factory set by using special equipment.

Insert sensor plug into socket, verifying that the wires on the plug exit as in the illustration. (See Figure 4-1 Typical Assembly/Disassembly).

1. Install three (3) standoff halves.
2. Install Electronic Assembly to Gauge Assembly.
3. Install three (3) screws on back of gauge.

IPT122 Series

LIMITED WARRANTY

Seller warrants that the Goods manufactured by Seller will be free from defects in materials or workmanship under normal use and service and that the Software will execute the programming instructions provided by Seller until the expiration of the earlier of twelve (12) months from the date of initial installation or eighteen (18) months from the date of shipment by Seller. Products purchased by Seller from a third party for resale to Buyer ("Resale Products") shall carry only the warranty extended by the original manufacturer.

All replacements or repairs necessitated by inadequate preventive maintenance, or by normal wear and usage, or by fault of Buyer, or by unsuitable power sources or by attack or deterioration under unsuitable environmental conditions, or by abuse, accident, alteration, misuse, improper installation, modification, repair, storage or handling, or any other cause not the fault of Seller are not covered by this limited warranty, and shall be at Buyer's expense.

Goods repaired and parts replaced during the warranty period shall be in warranty for the remainder of the original warranty period or ninety (90) days, whichever is longer. This limited warranty is the only warranty made by Seller and can be amended only in a writing signed by an authorized representative of Seller.

BROOKS SERVICE AND SUPPORT

Brooks is committed to assuring all of our customers receive the ideal flow solution for their application, along with outstanding service and support to back it up. We operate first class repair facilities located around the world to provide rapid response and support. Each location utilizes primary standard calibration equipment to ensure accuracy and reliability for repairs and recalibration and is certified by our local Weights and Measures Authorities and traceable to the relevant International Standards.

Visit www.BrooksInstrument.com to locate the service location nearest to you.

START-UP SERVICE AND IN-SITU CALIBRATION

Brooks Instrument can provide start-up service prior to operation when required.

For some process applications, where ISO-9001 Quality Certification is important, it is mandatory to verify and/or (re)calibrate the products periodically. In many cases this service can be provided under in-situ conditions, and the results will be traceable to the relevant international quality standards.

CUSTOMER SEMINARS AND TRAINING

Brooks Instrument can provide customer seminars and dedicated training to engineers, end users and maintenance persons.

Please contact your nearest sales representative for more details.

HELP DESK

In case you need technical assistance:

- Americas ☎ 1 888 554 FLOW
- Europe ☎ +31 (0) 318 549 290
- Asia ☎ +81 (0) 3 5633 7100



Due to Brooks Instrument's commitment to continuous improvement of our products, all specifications are subject to change without notice.

Supersedes Doc.# A331666 Rev 002

TRADEMARKS

Brooks Brooks Instrument, LLC

Brooks Instrument
 407 West Vine Street
 P.O. Box 903
 Hatfield, PA 19440-0903 USA
 T (215) 362 3700
 F (215) 362 3745
 E-Mail BrooksAm@BrooksInstrument.com
www.BrooksInstrument.com

Brooks Instrument
 Neonstraat
 6718 WX Ede, Netherlands
 T +31 (0) 318 549 300
 F +31 (0) 318 549 309
 E-Mail BrooksEu@BrooksInstrument.com

Brooks Instrument
 1-4-4 Kitasuna Koto-Ku
 Tokyo, 136-0073 Japan
 T +81 (0) 3 5633 7100
 F +81 (0) 3 5633 7101
 E-Mail BrooksAs@BrooksInstrument.com

